

Patryk Wójtowicz

AutoCAD – Fundamentals
AutoCAD – Podstawy

BASIC EXERCISE PACK
ZESTAW ĆWICZEŃ PODSTAWOWYCH

Exercises comments

- Please save drawings in one file in folder (use your name as a description) on local hard drive or on your flash drive (recommended!)
- Some drawings will be edited or used in another exercises

Exercise 1

Instructions:

- Draw rectangle using line tool using:
 - line tool and command prompt
 - dynamic input
 - “ortho” lock (F8)

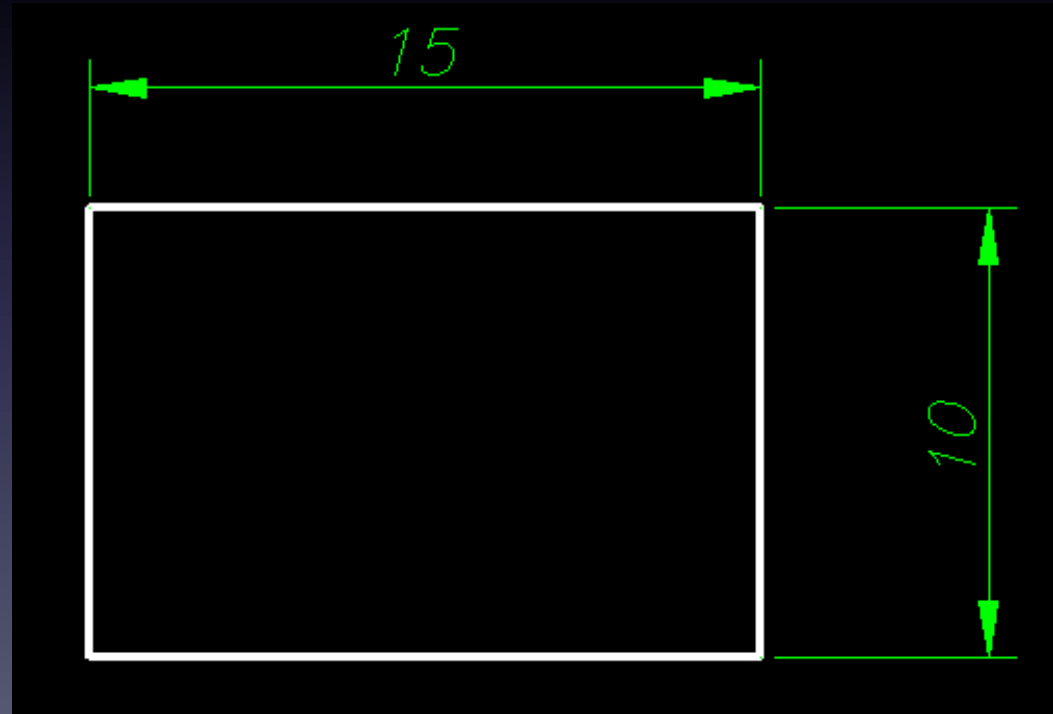

Exercise 2

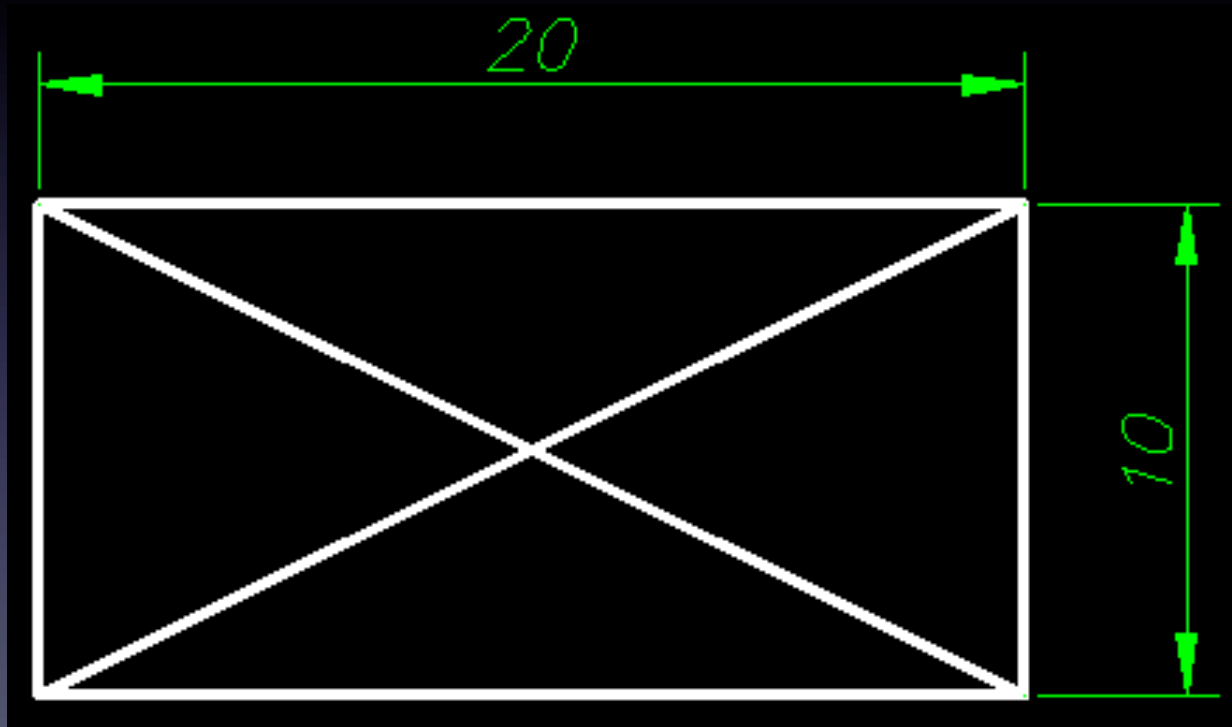

Exercise 3

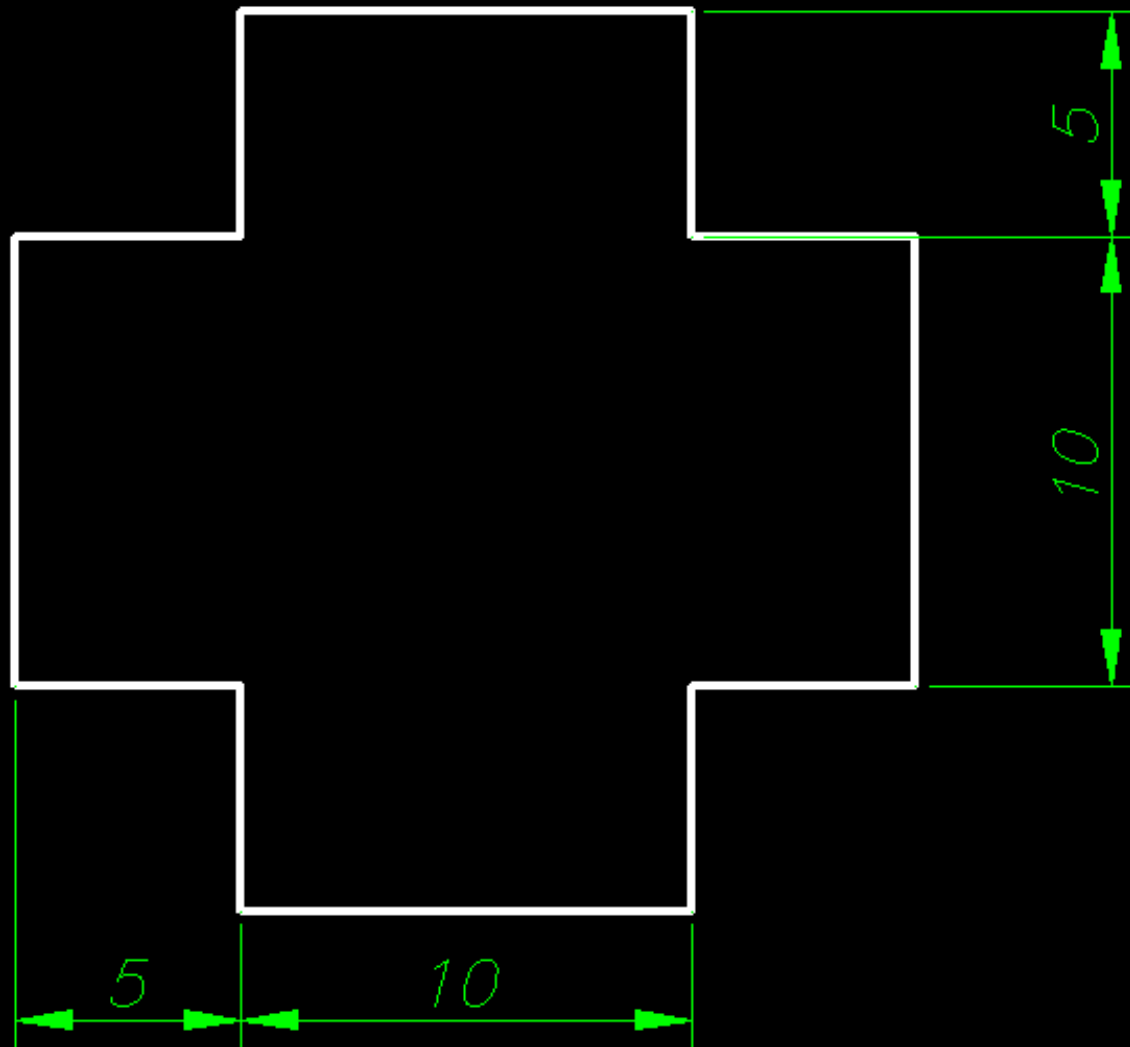

Exercise 4

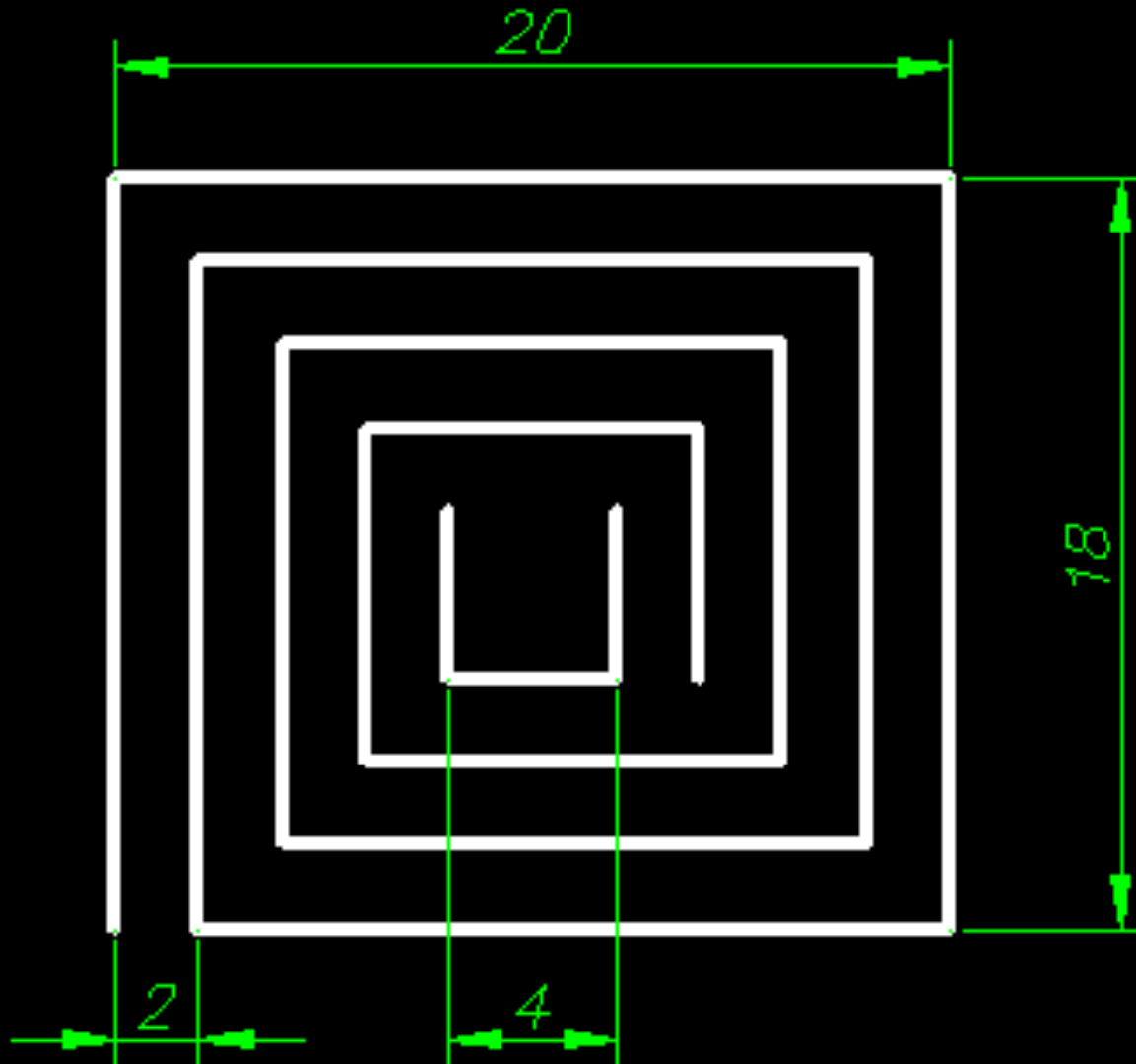

Exercise 5

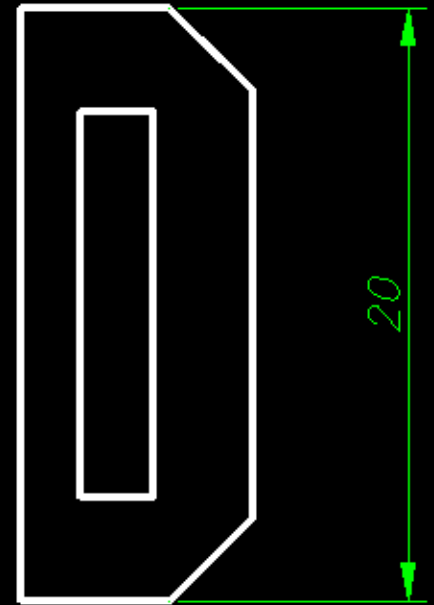
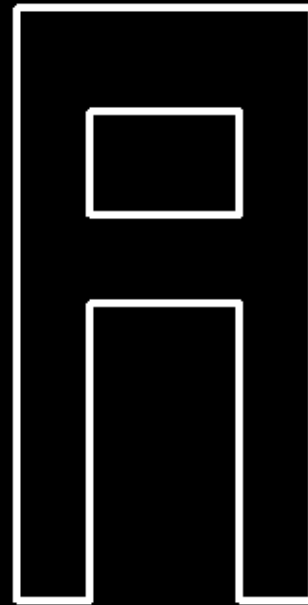
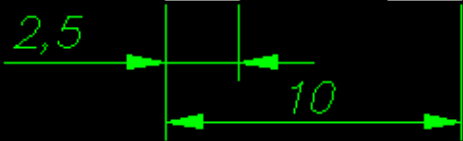
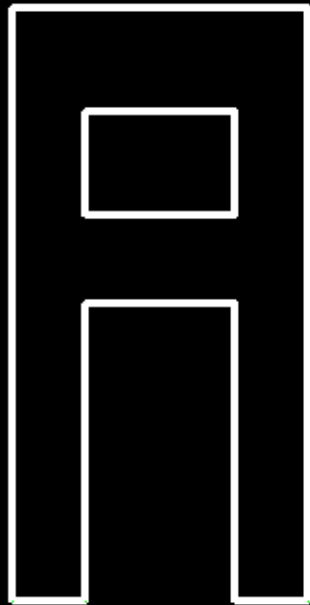

20

Exercise 6

- *Hint:* use editing points to adjust shape of arc

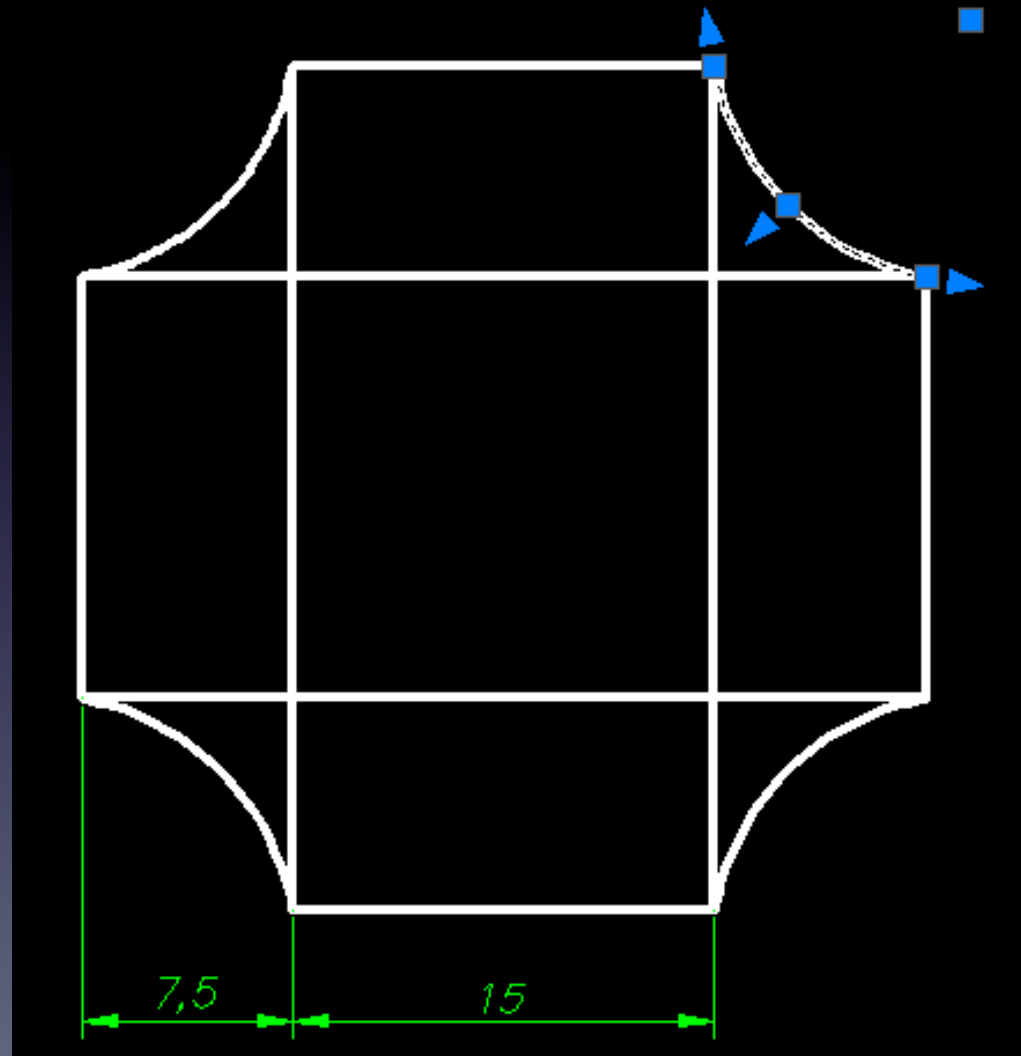

Exercise 7

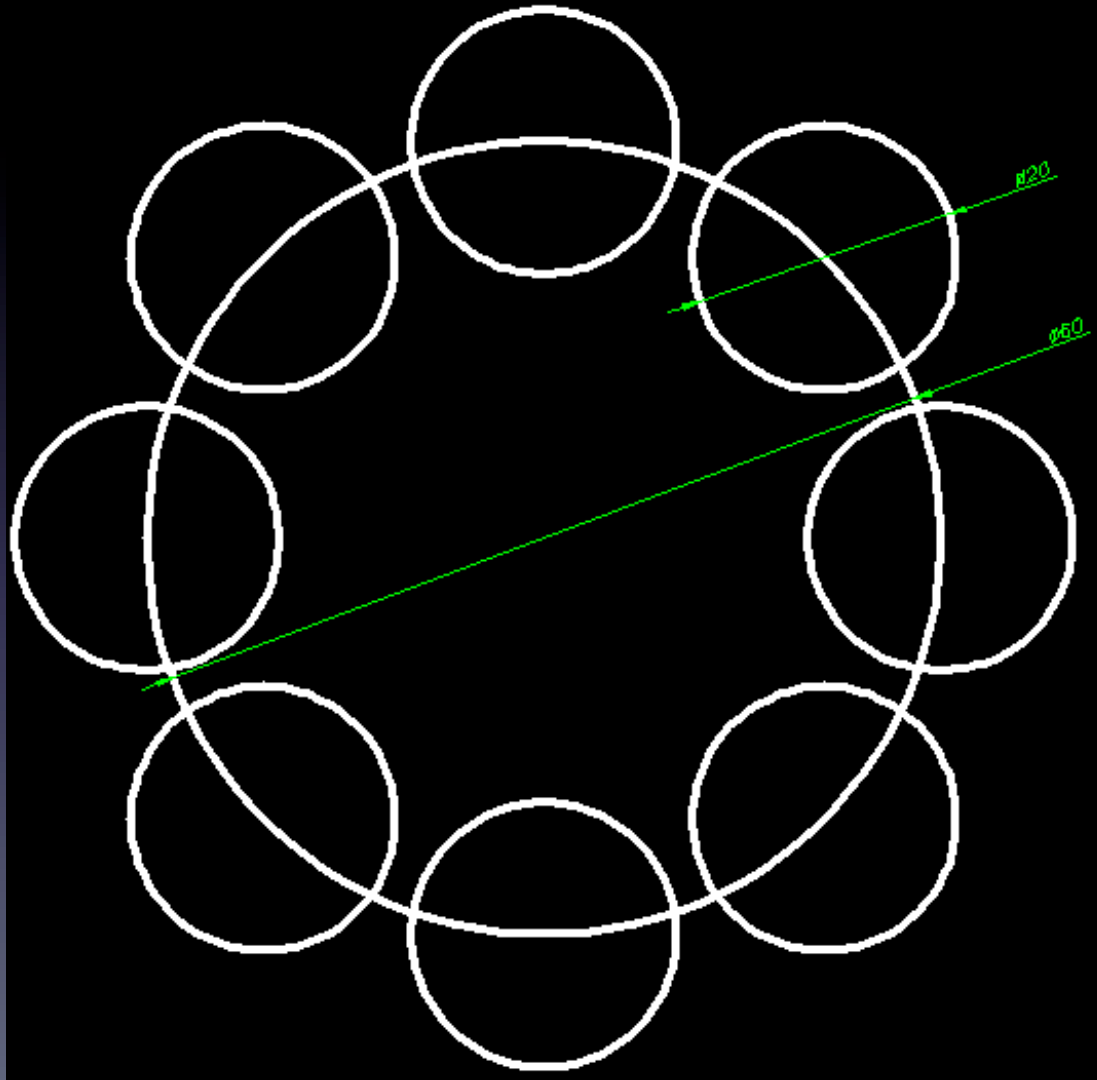

Exercise 8

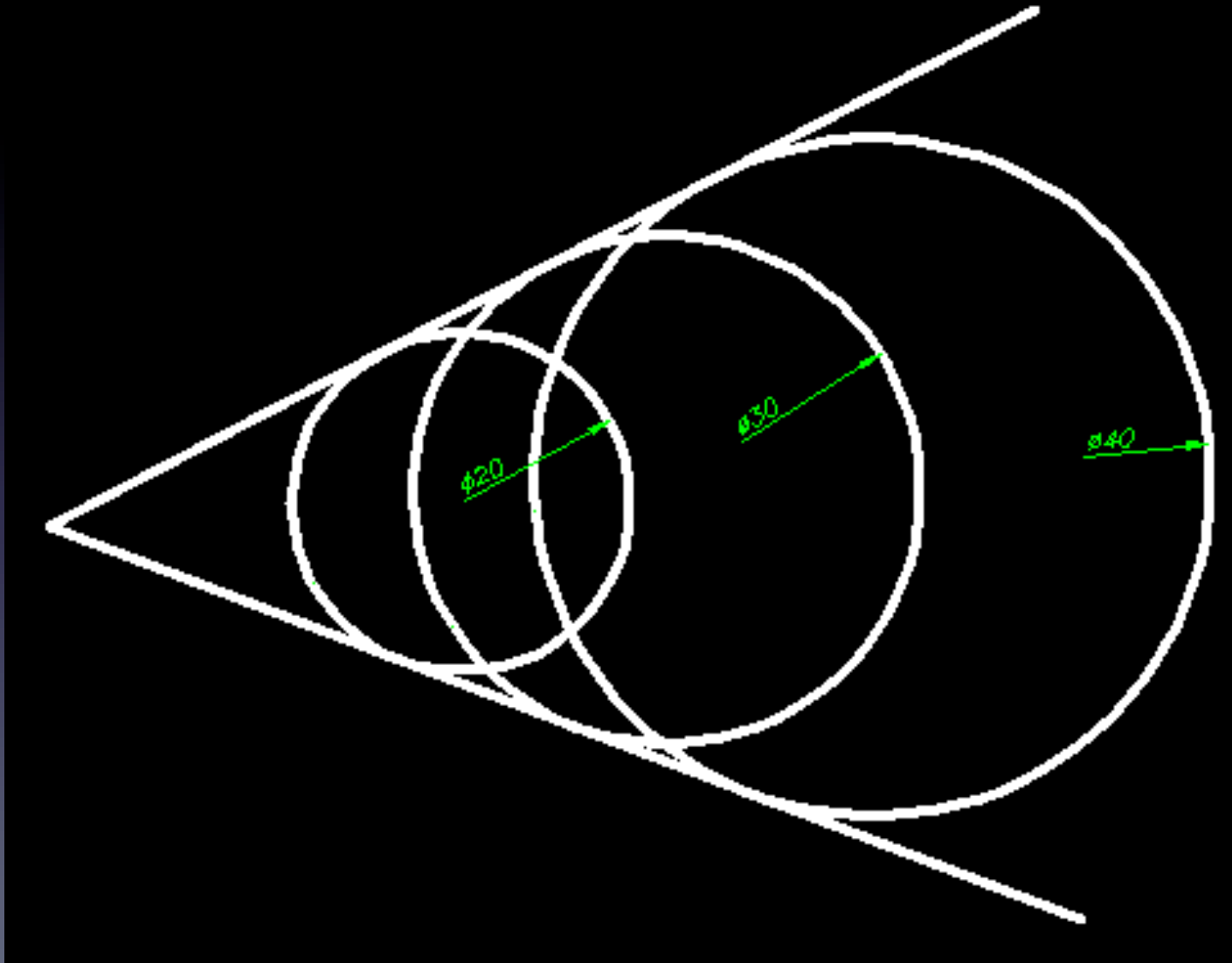

Exercise 9

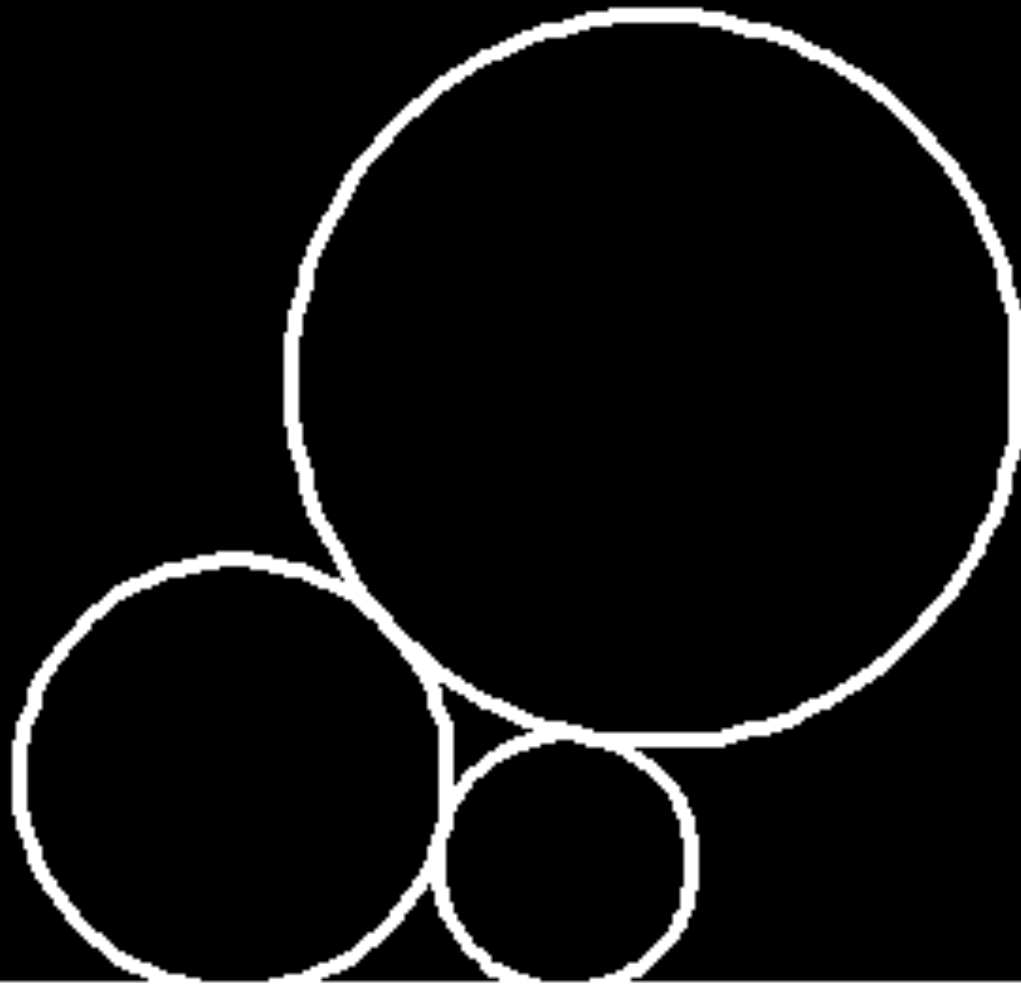

Exercise 10

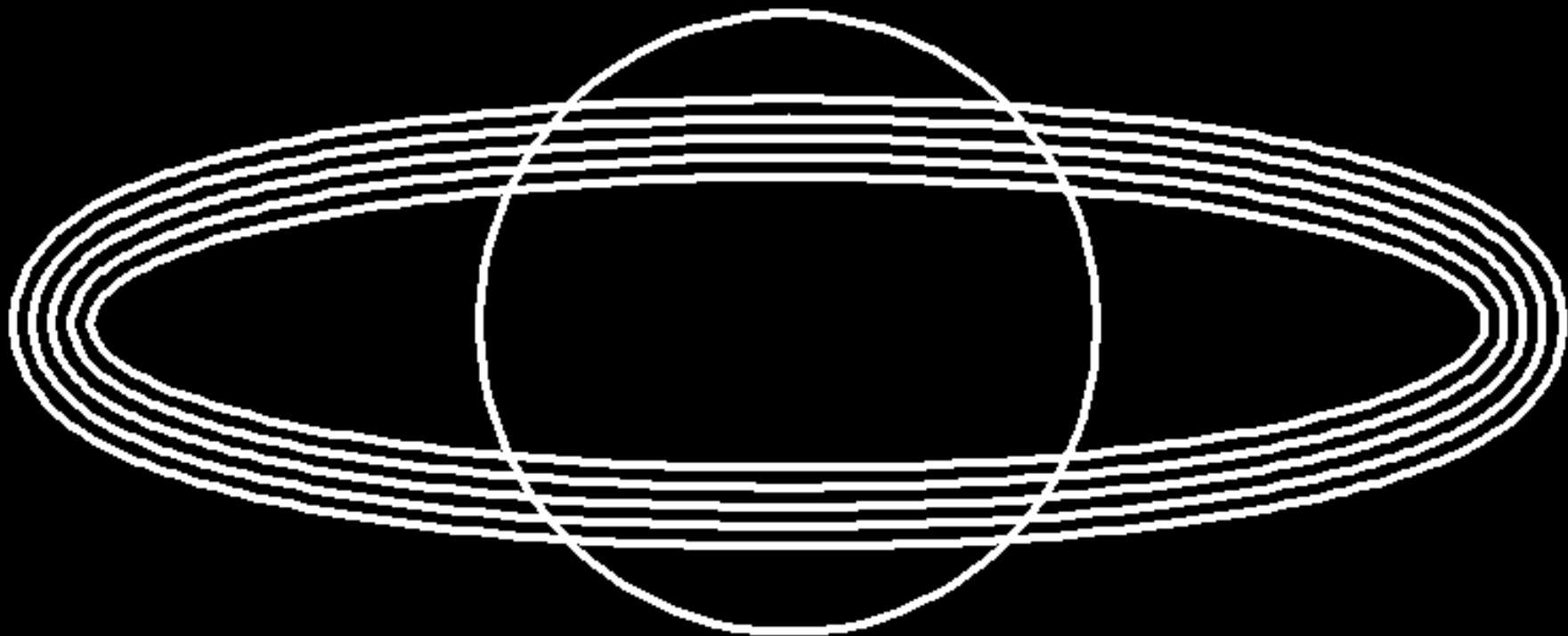

Exercise 11

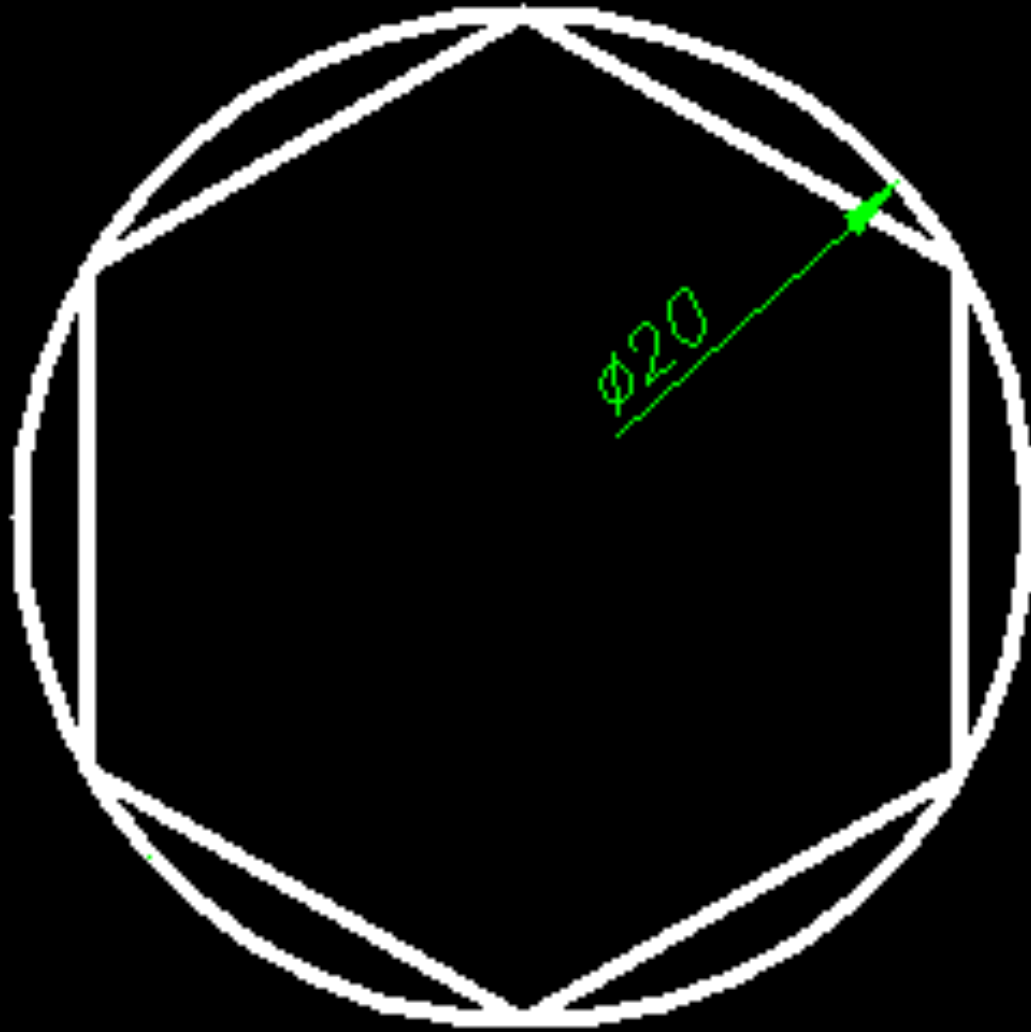

Exercise 12

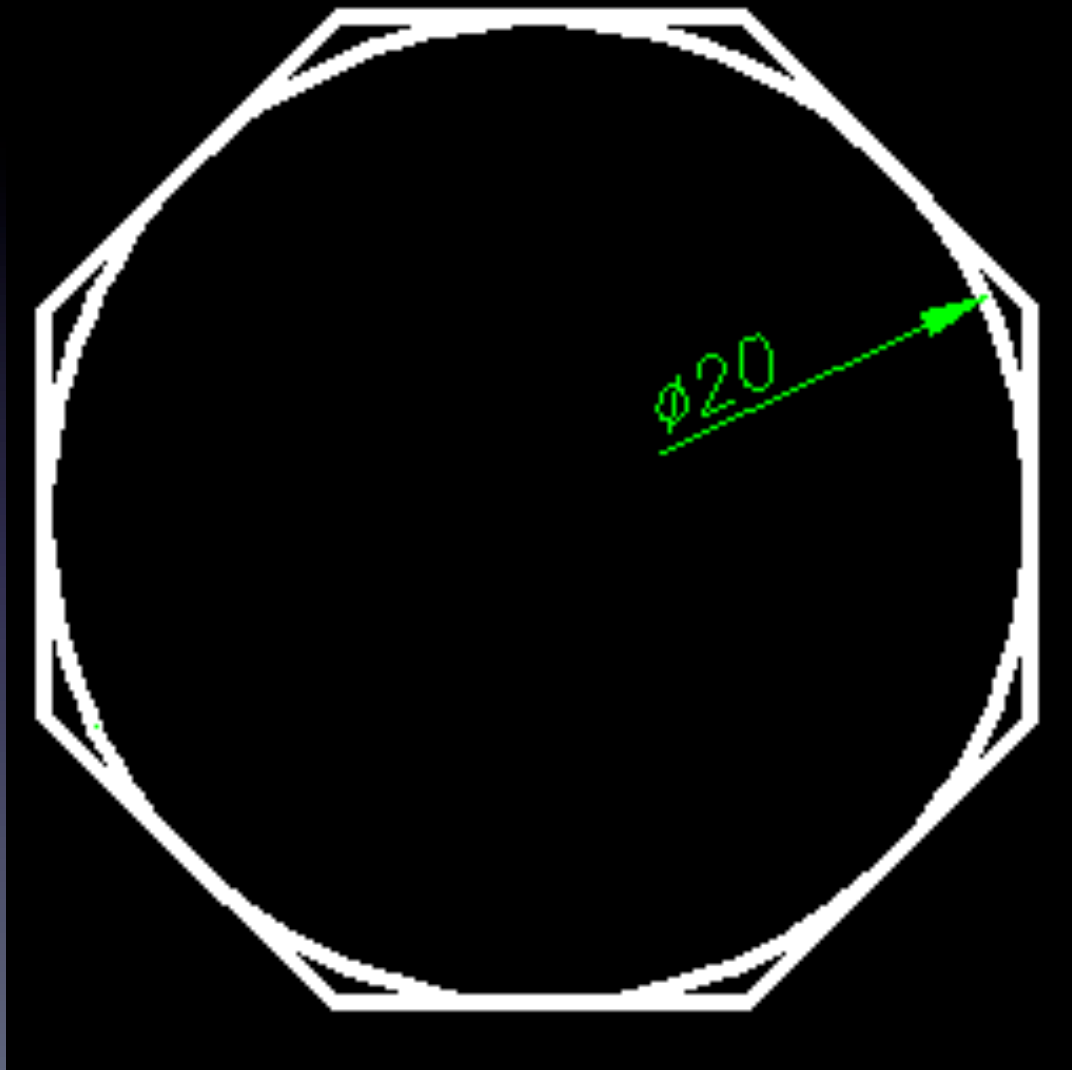

Exercise 13

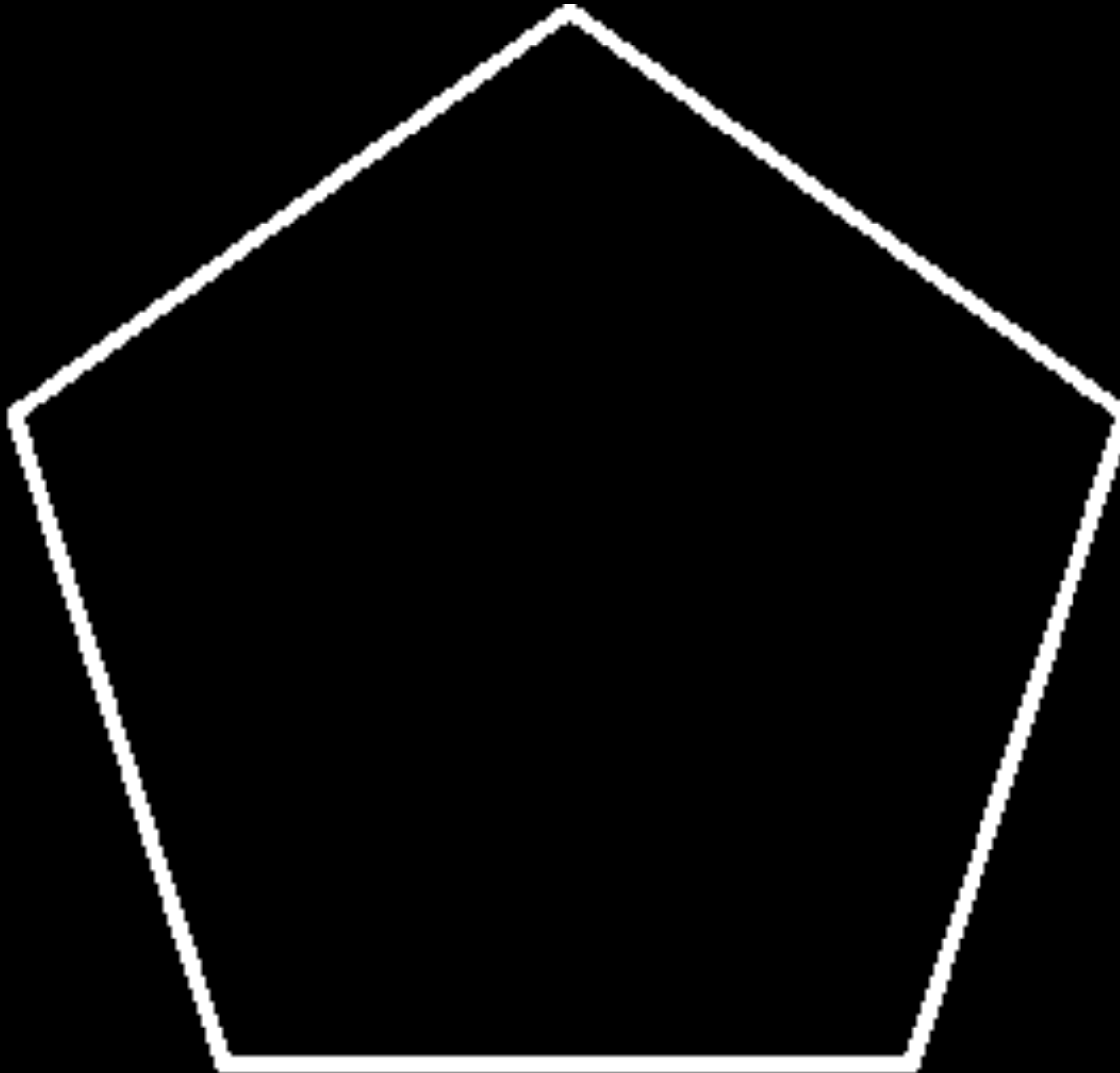

Exercise 14

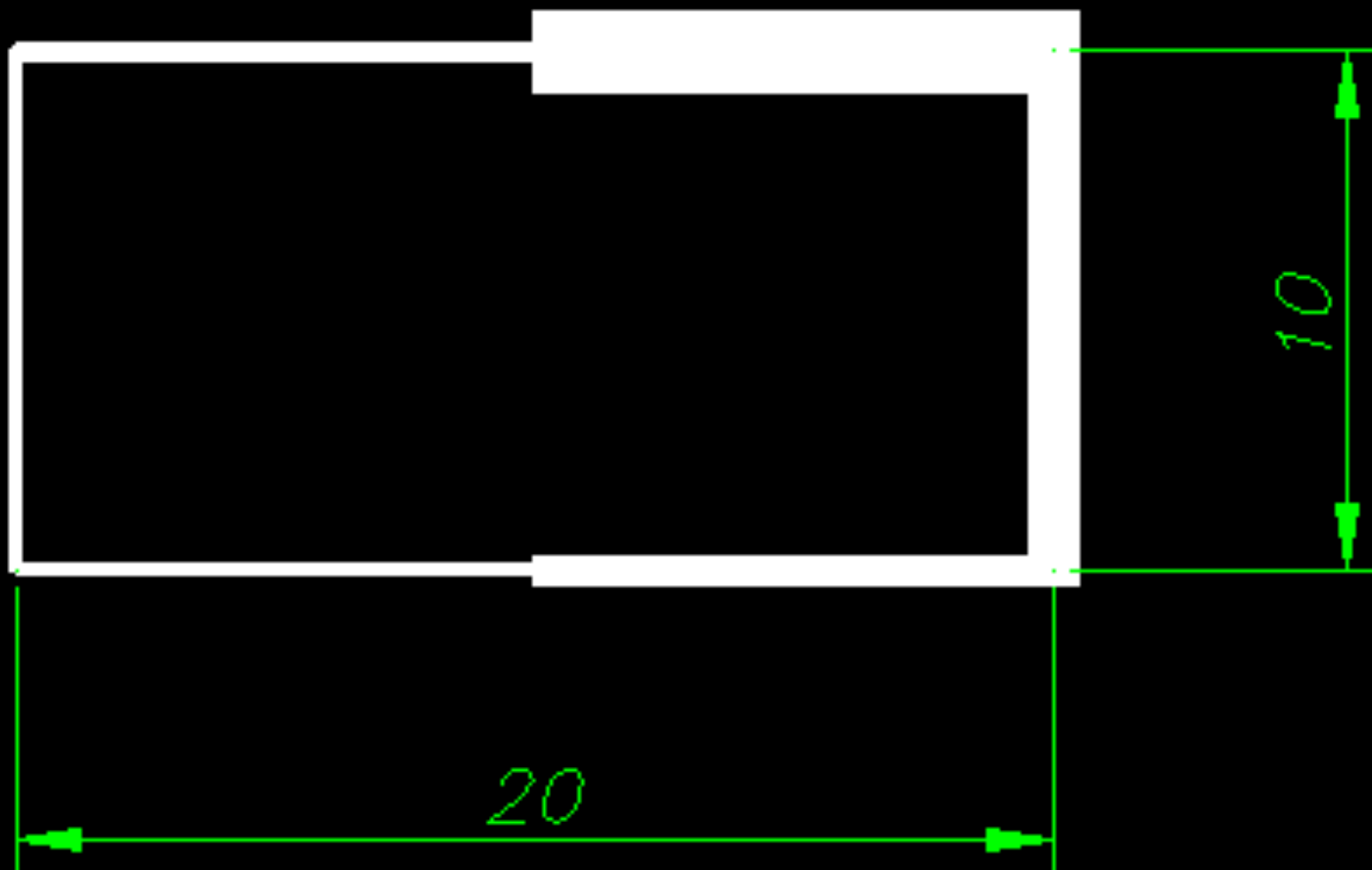

Exercise 15

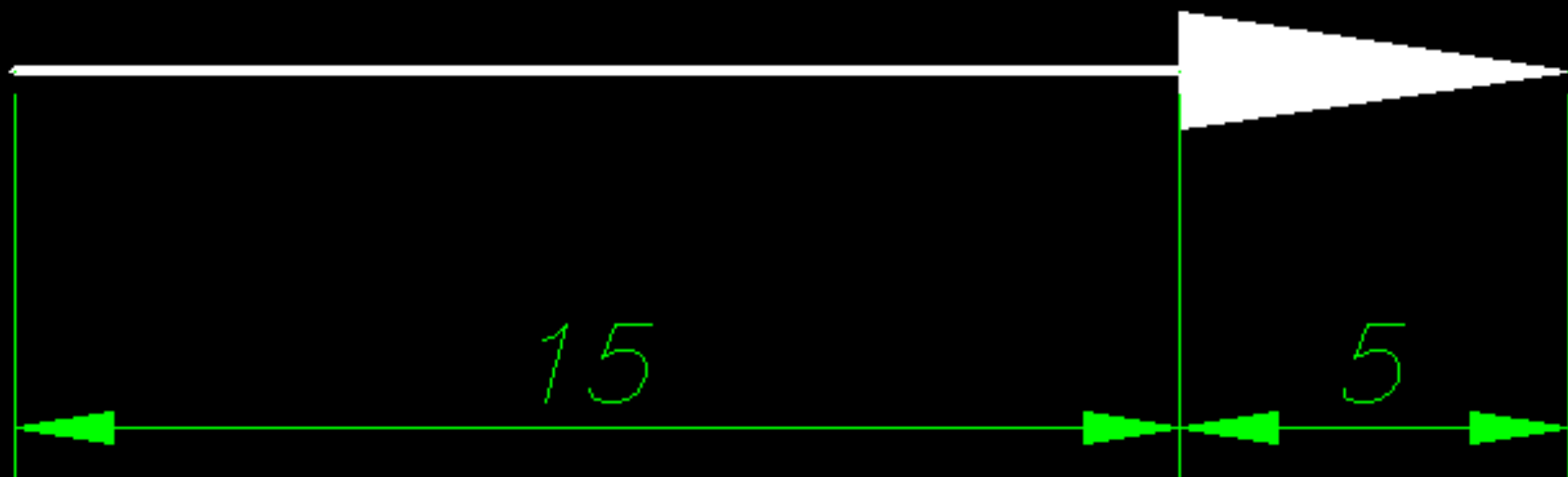

Exercise 16



Exercise 17

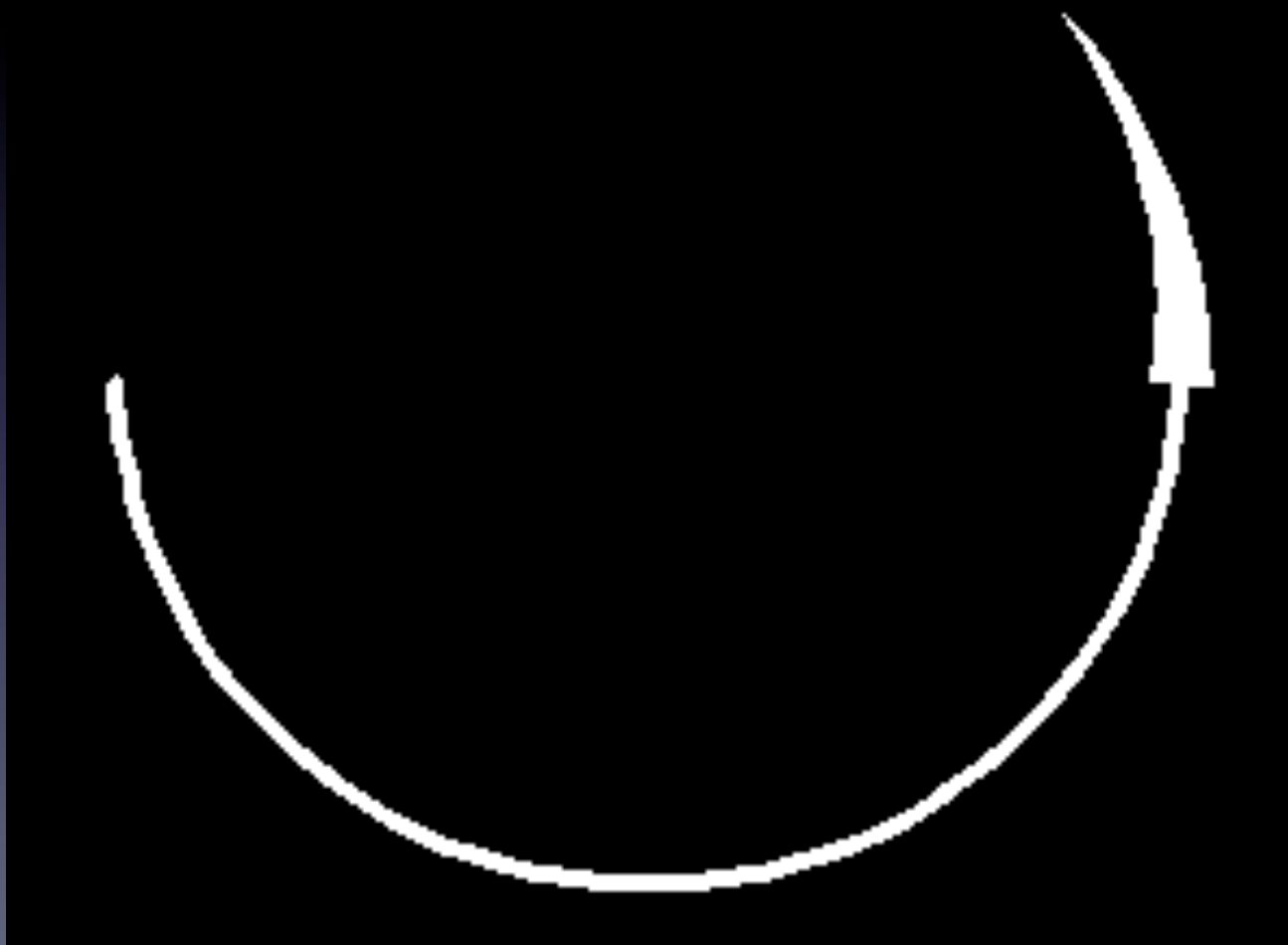

Exercise 18

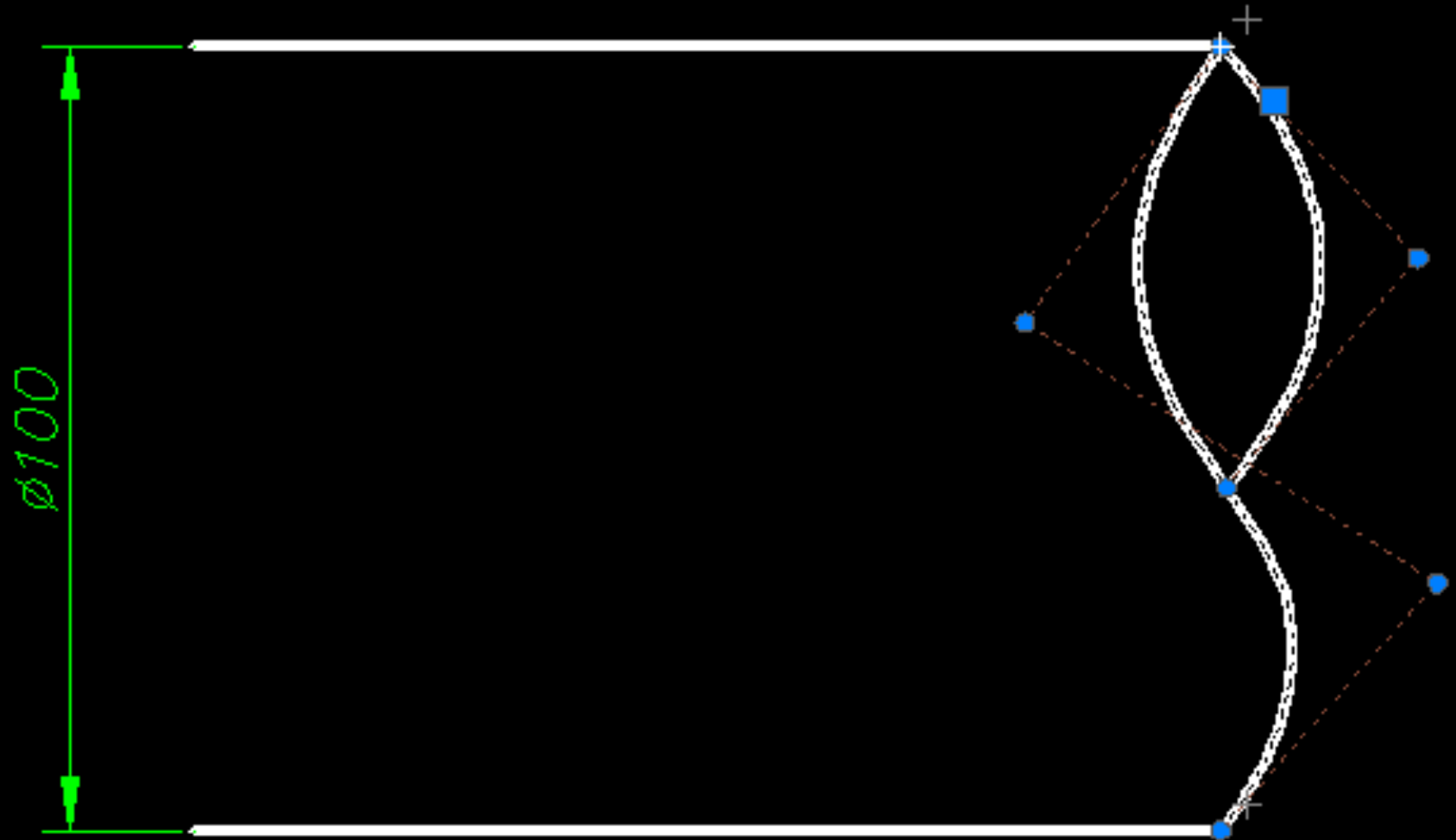

Exercise 19

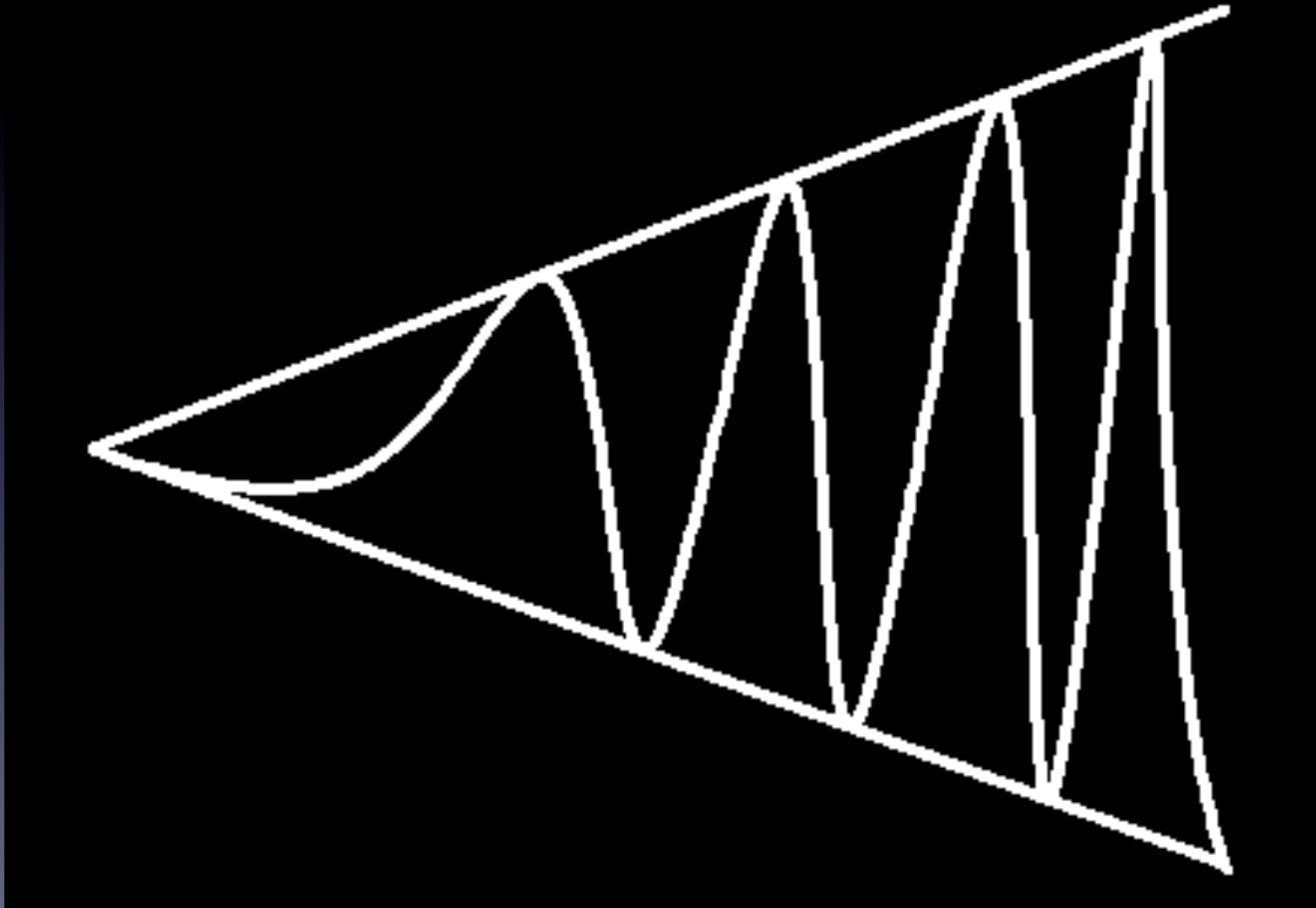

Exercise 20

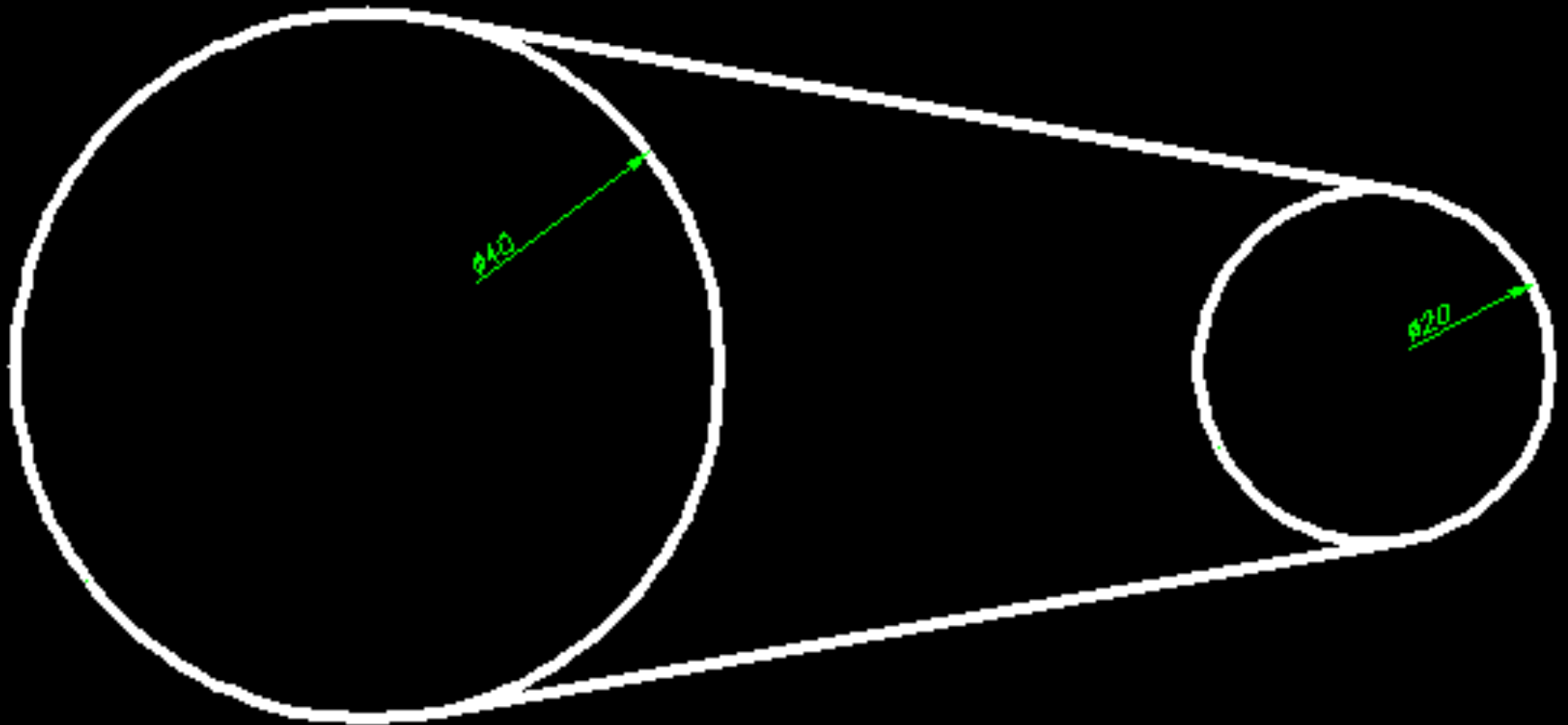

Exercise 21

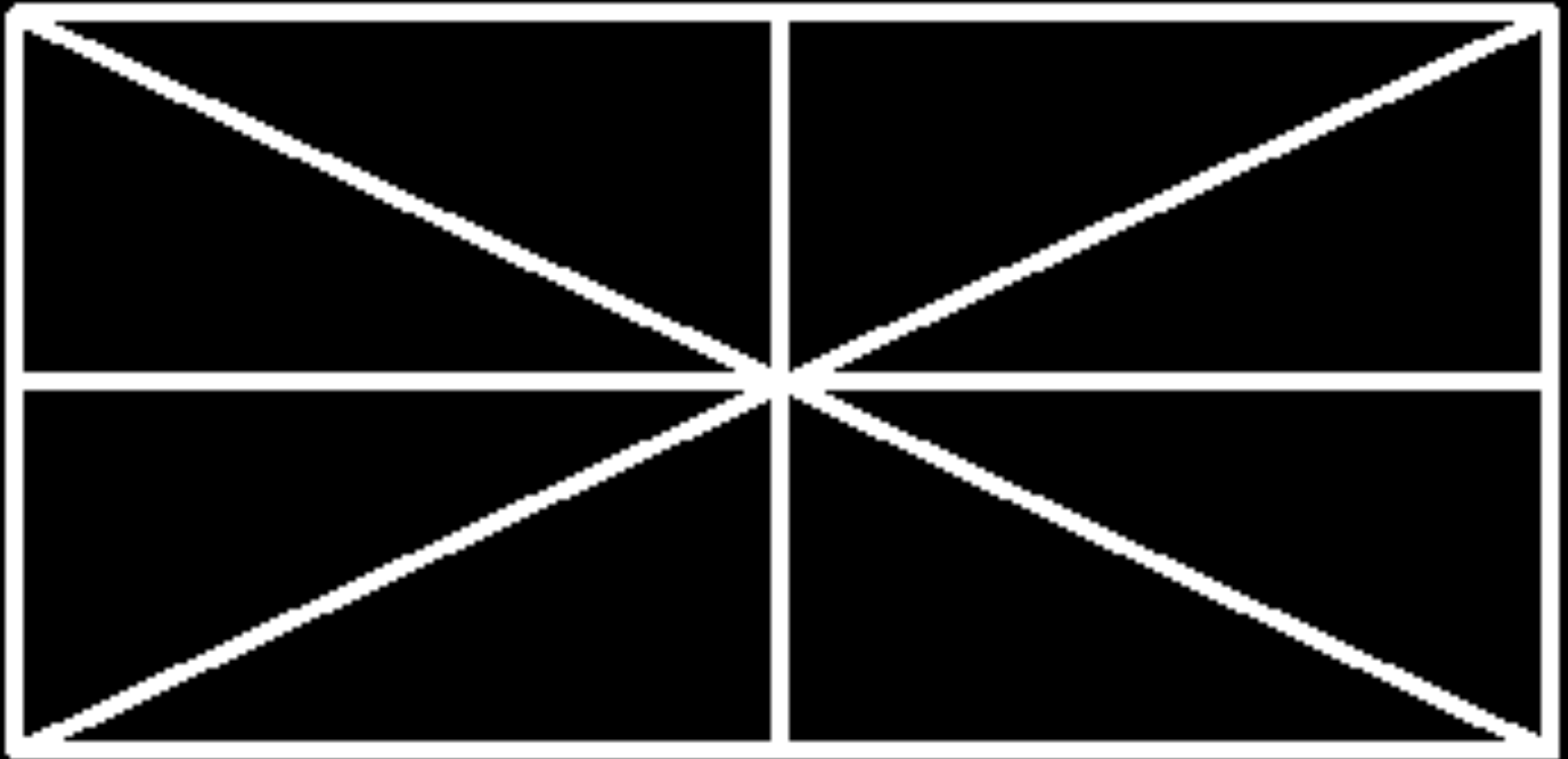

Exercise 22

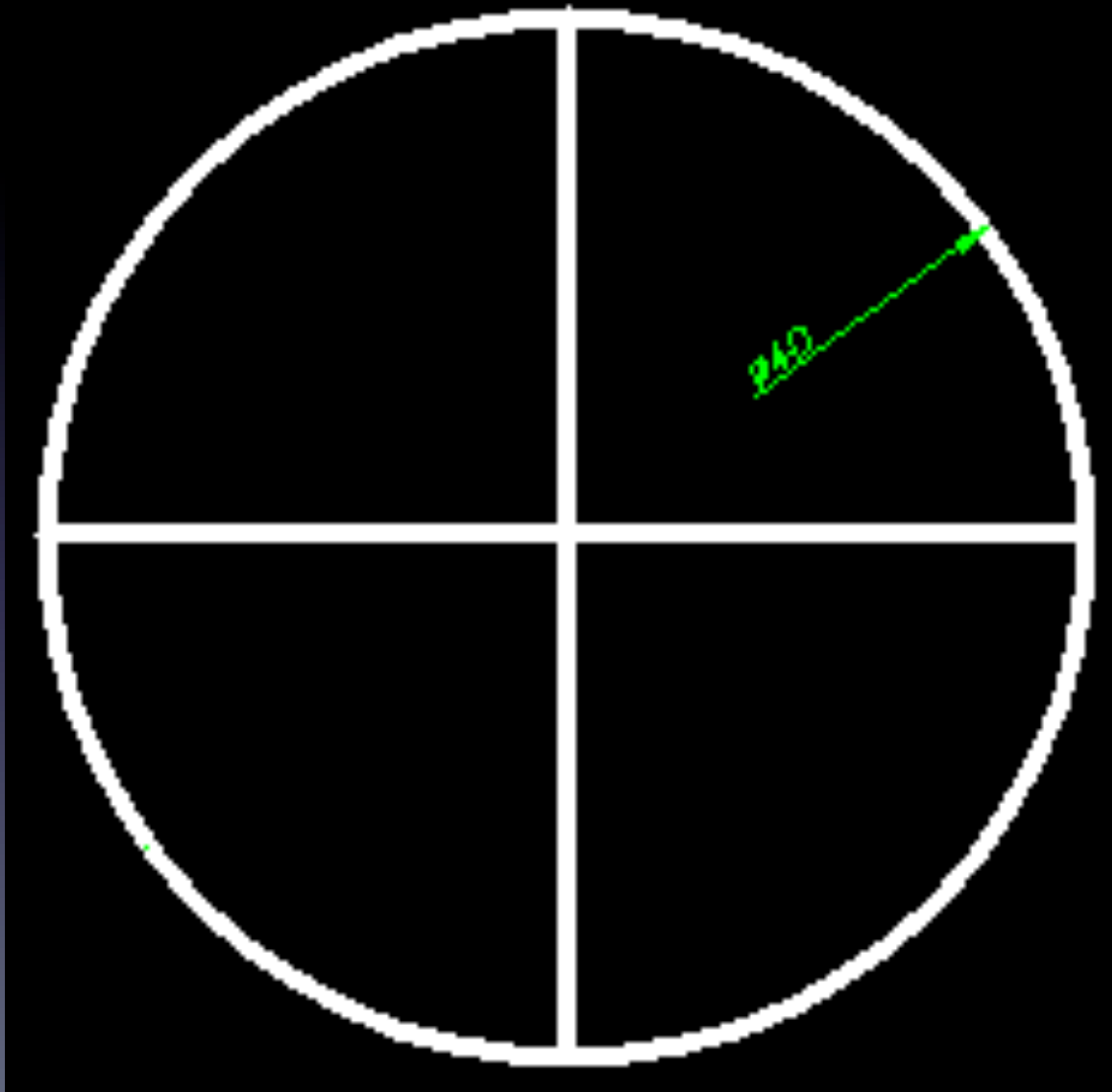

Exercise 23



Exercise 24

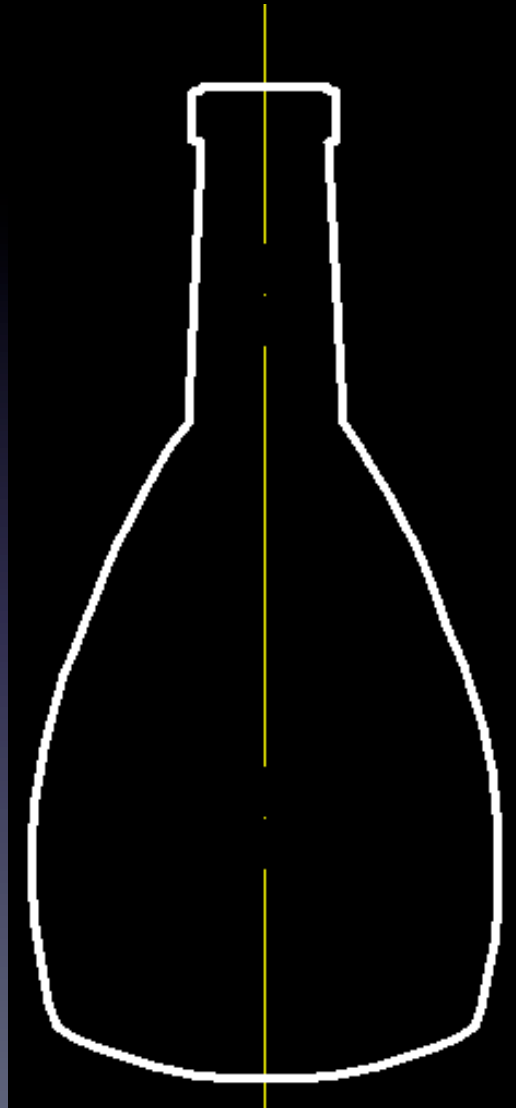

Exercise 25

- Shape “classic” Coca-Cola bottle using **MIRROR** command



Exercise 26

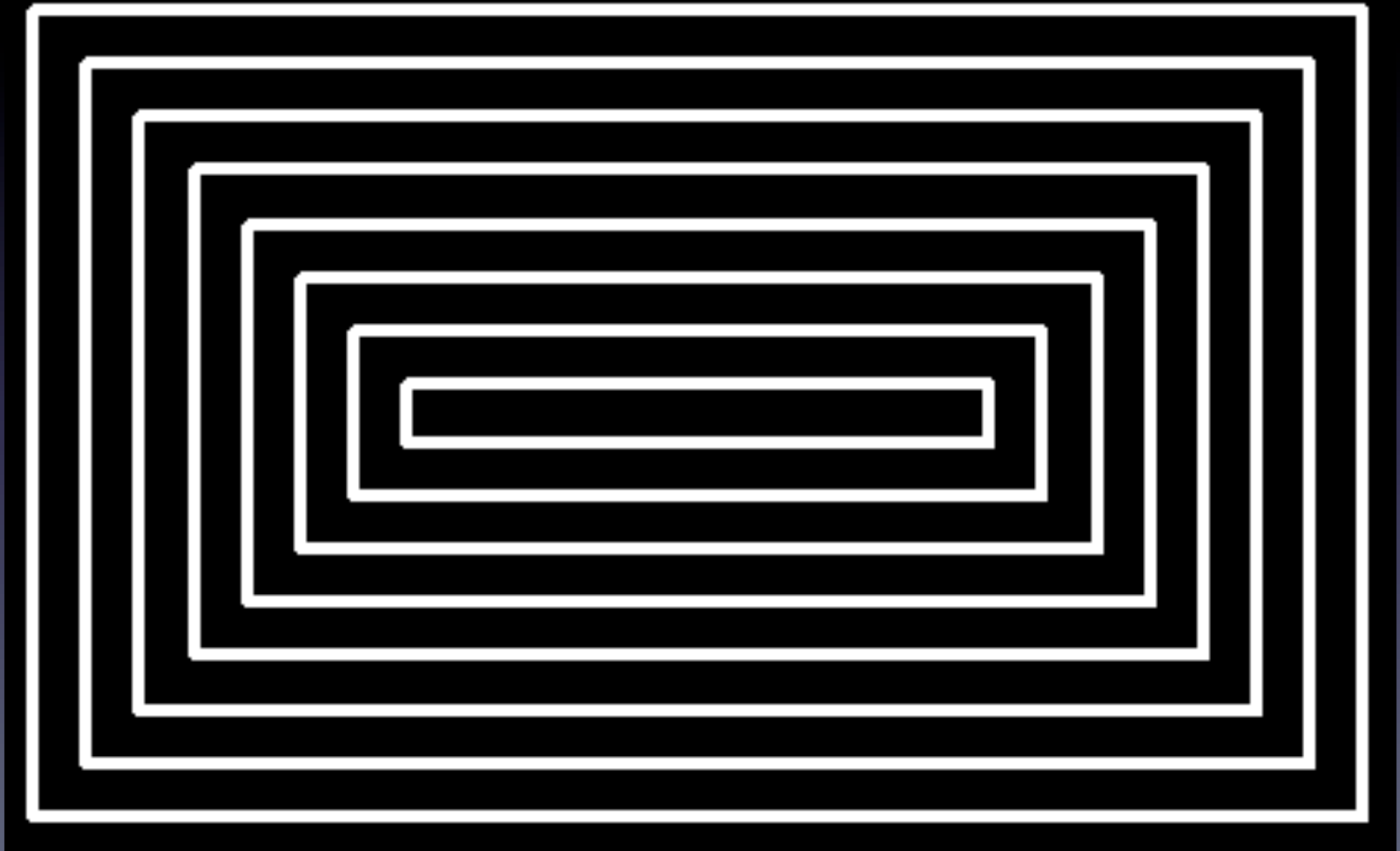

Exercise 27

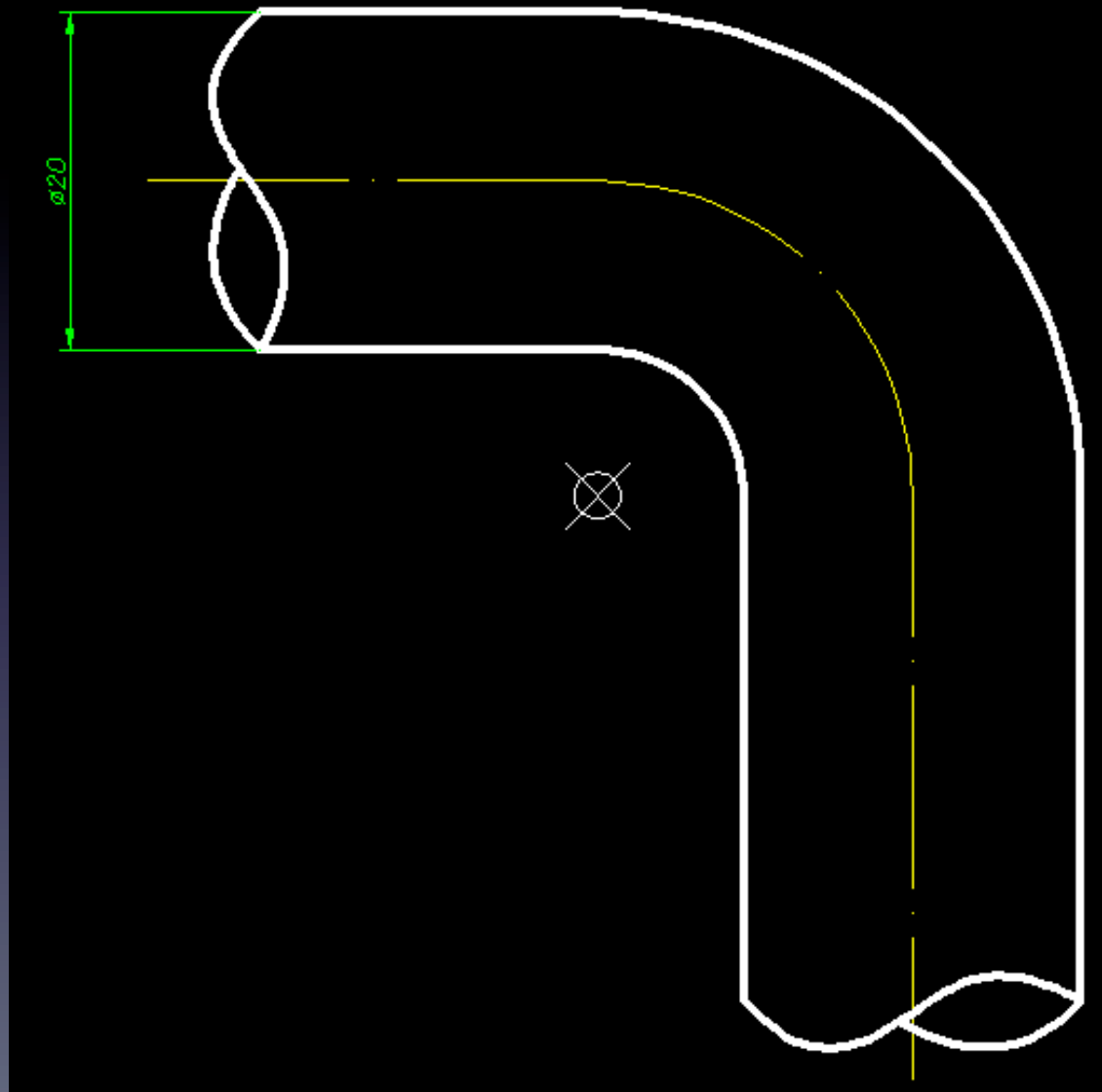

Exercise 28

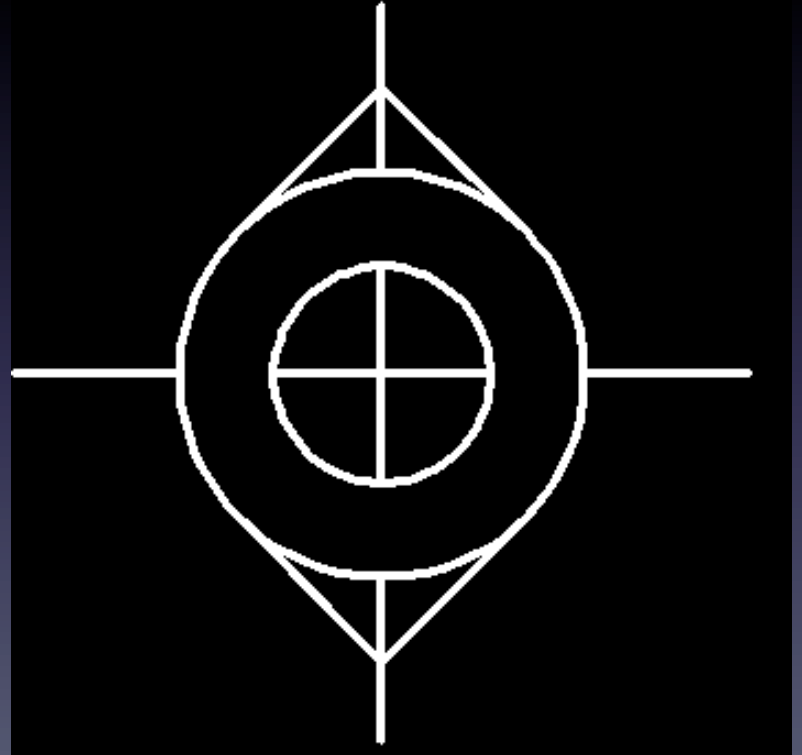
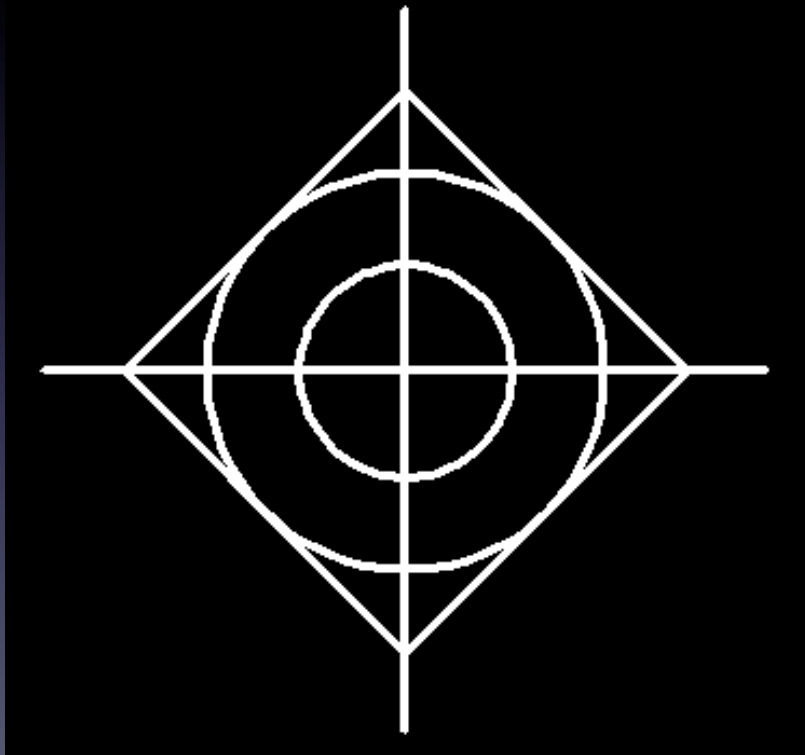

Exercise 29

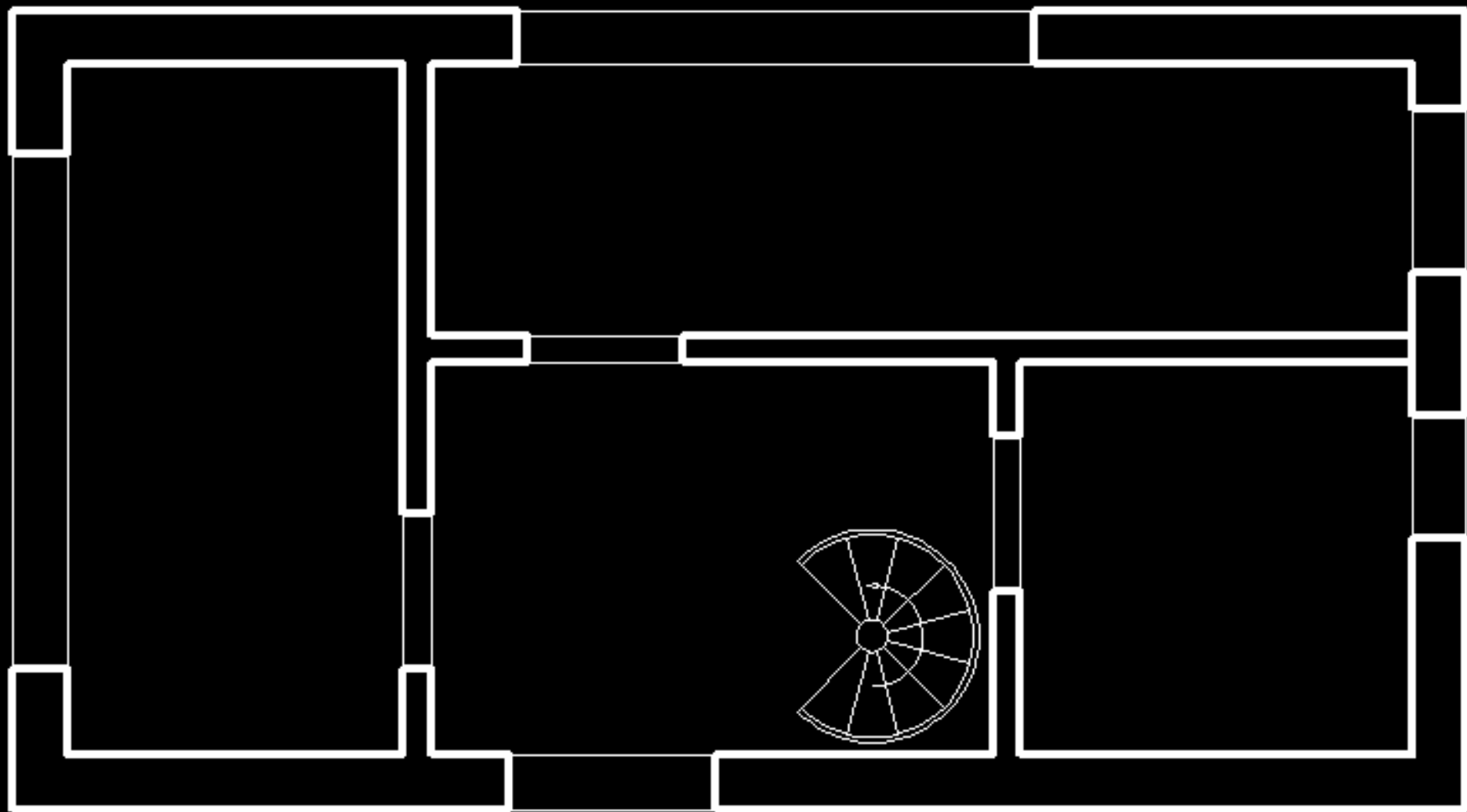

Exercise 30



Exercise 31



Exercise 32

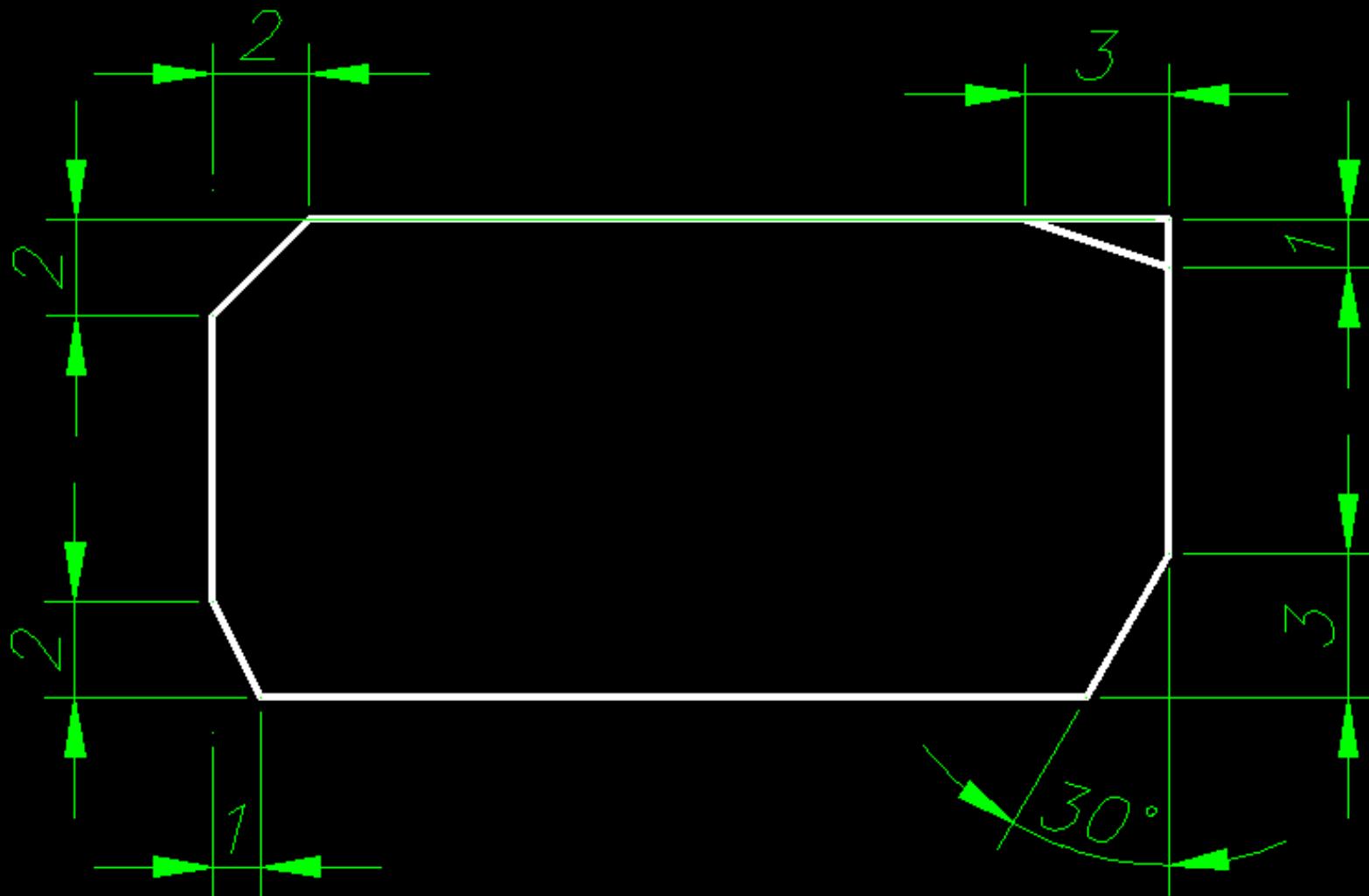

Exercise 33

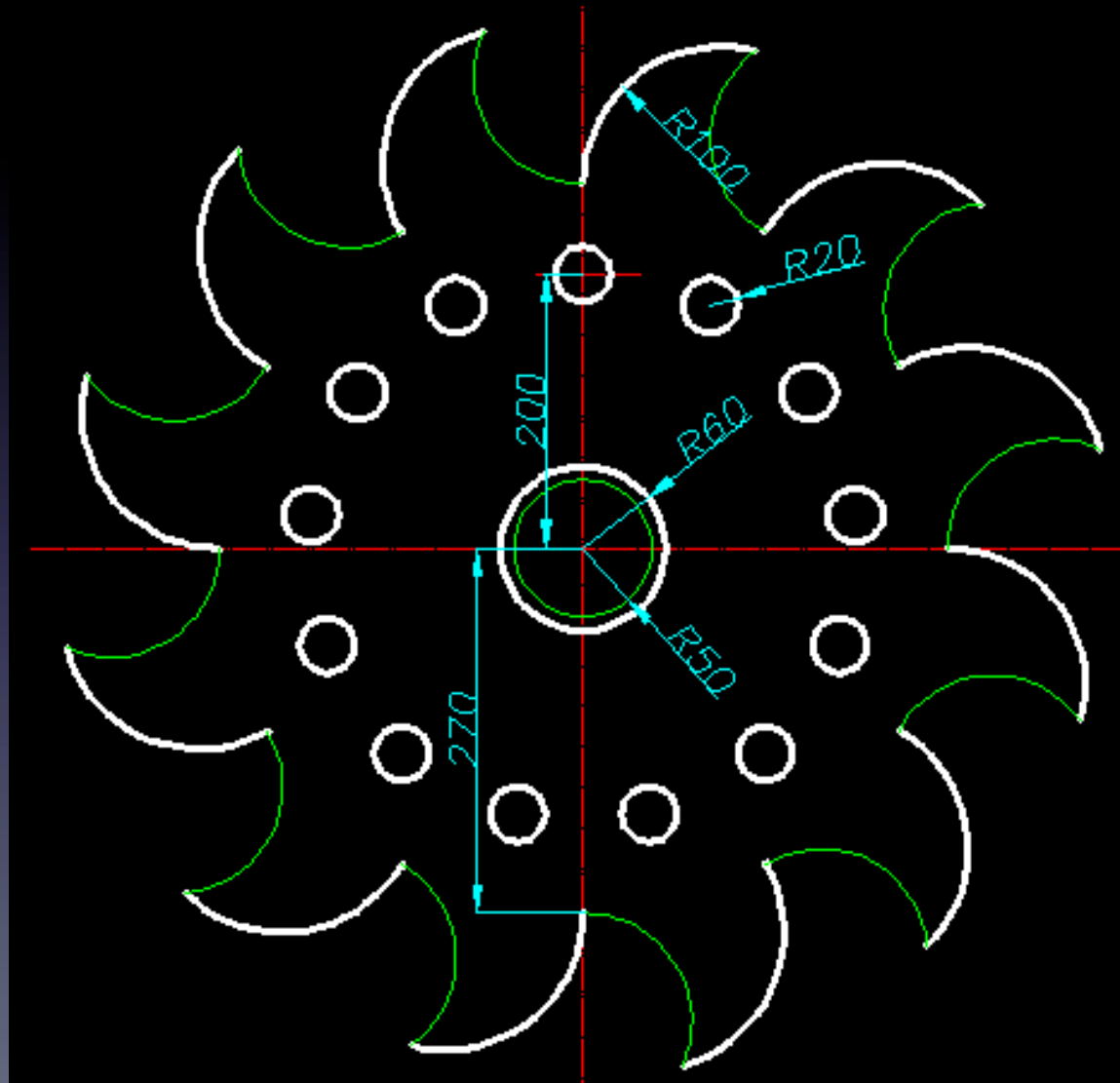

Exercise 34

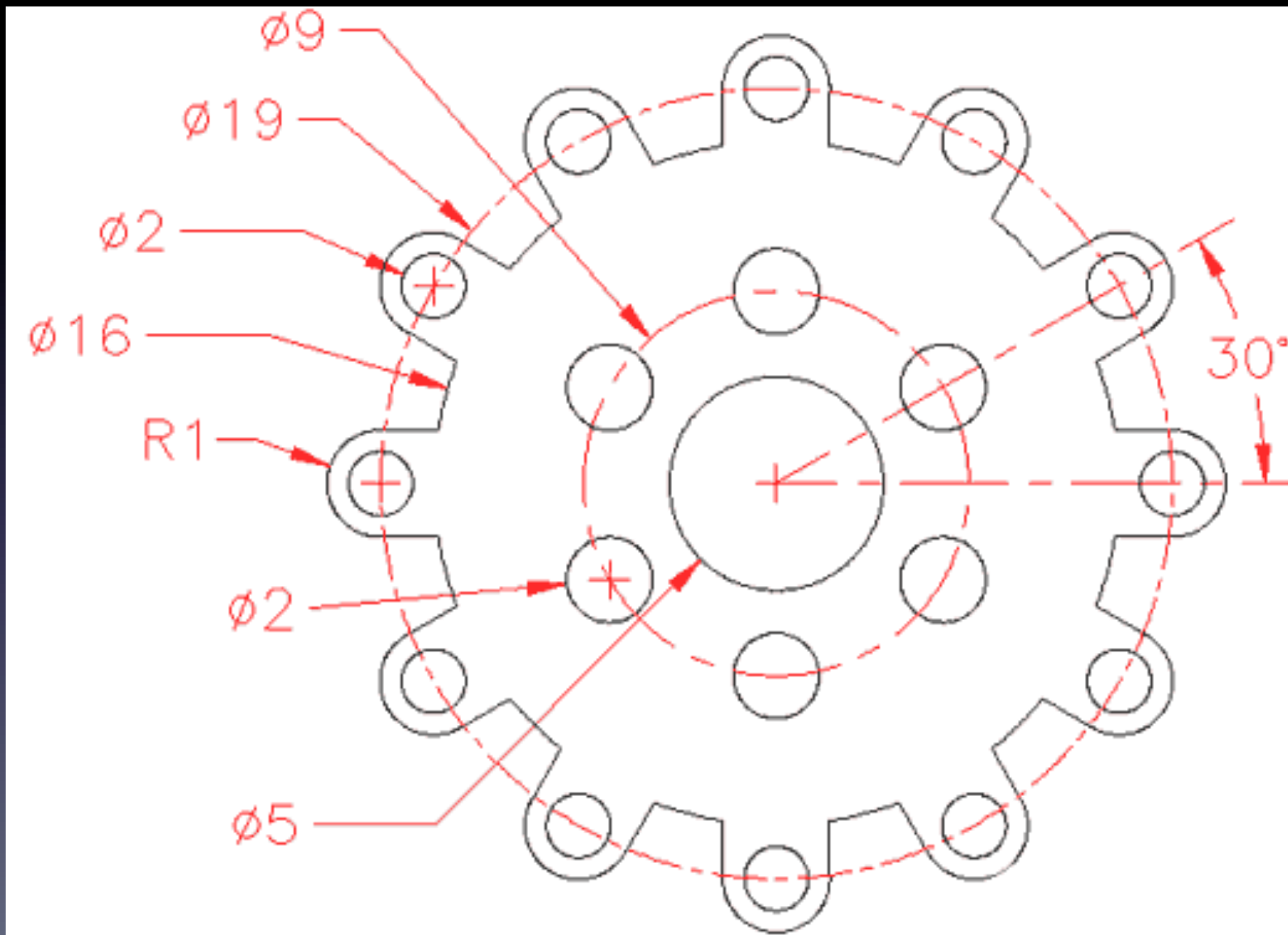

Exercise 35

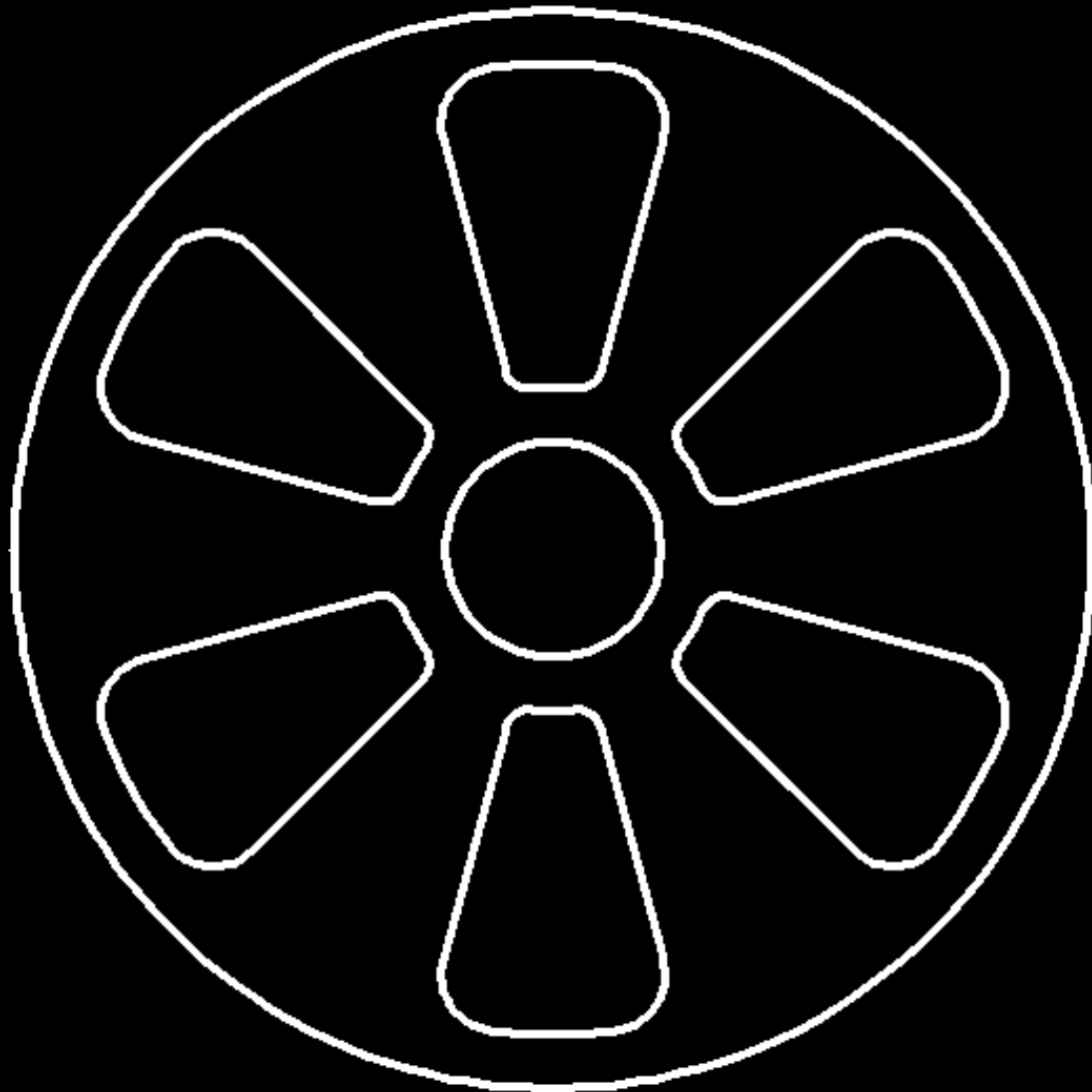

Exercise 36

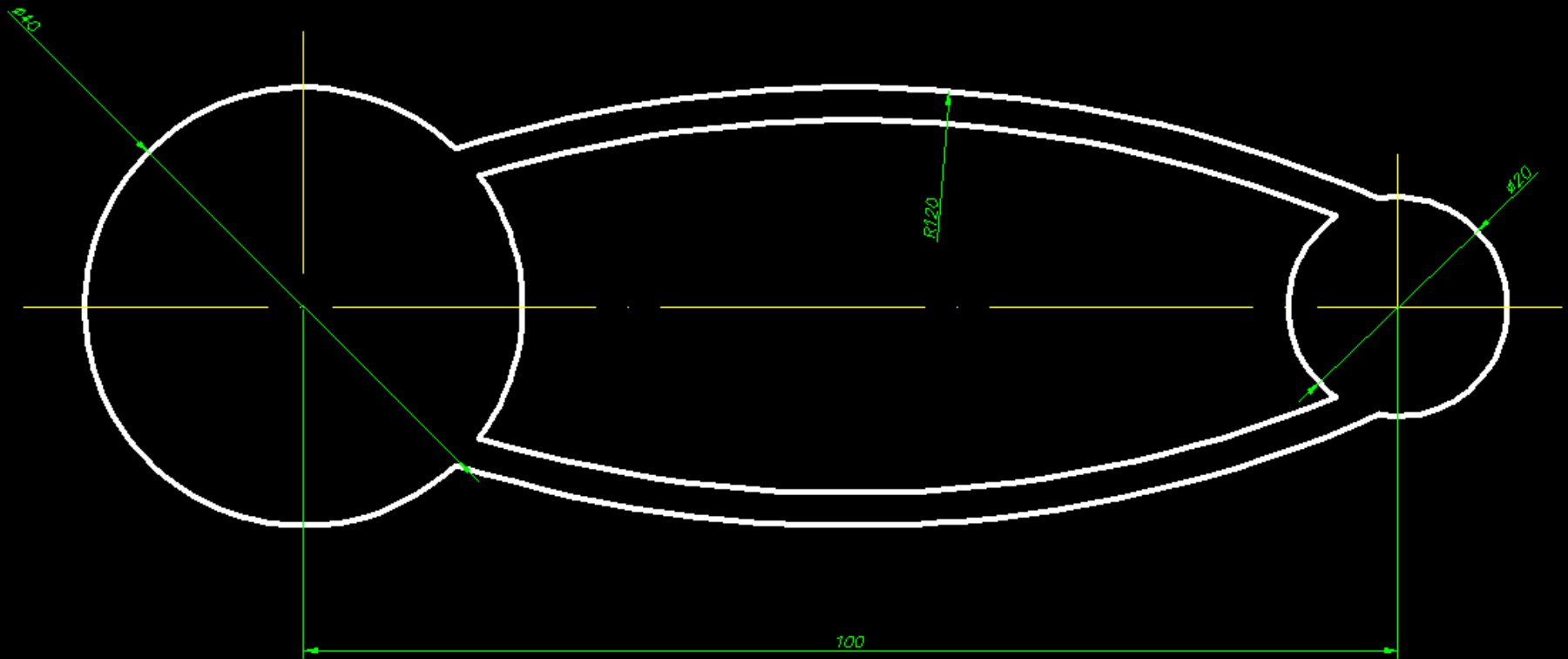

Exercise 37

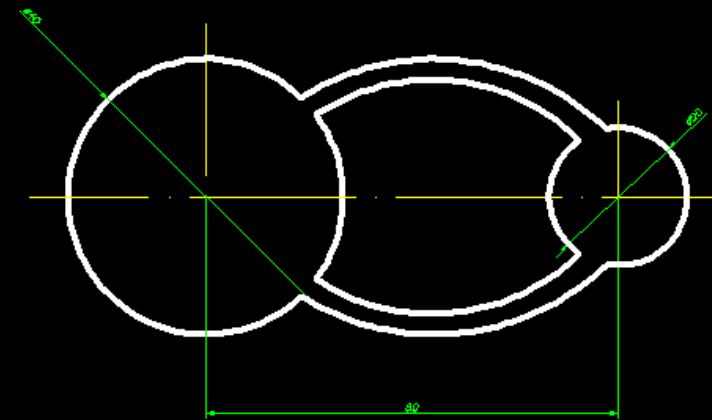
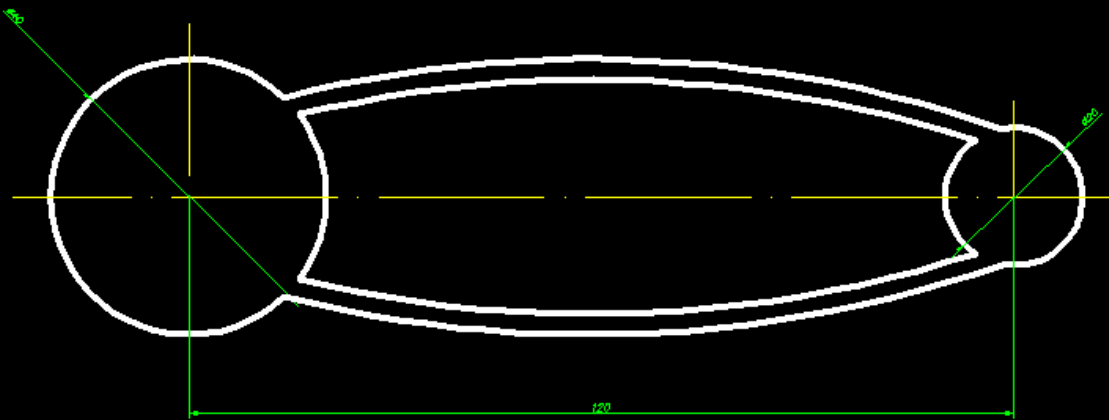

Exercise 38

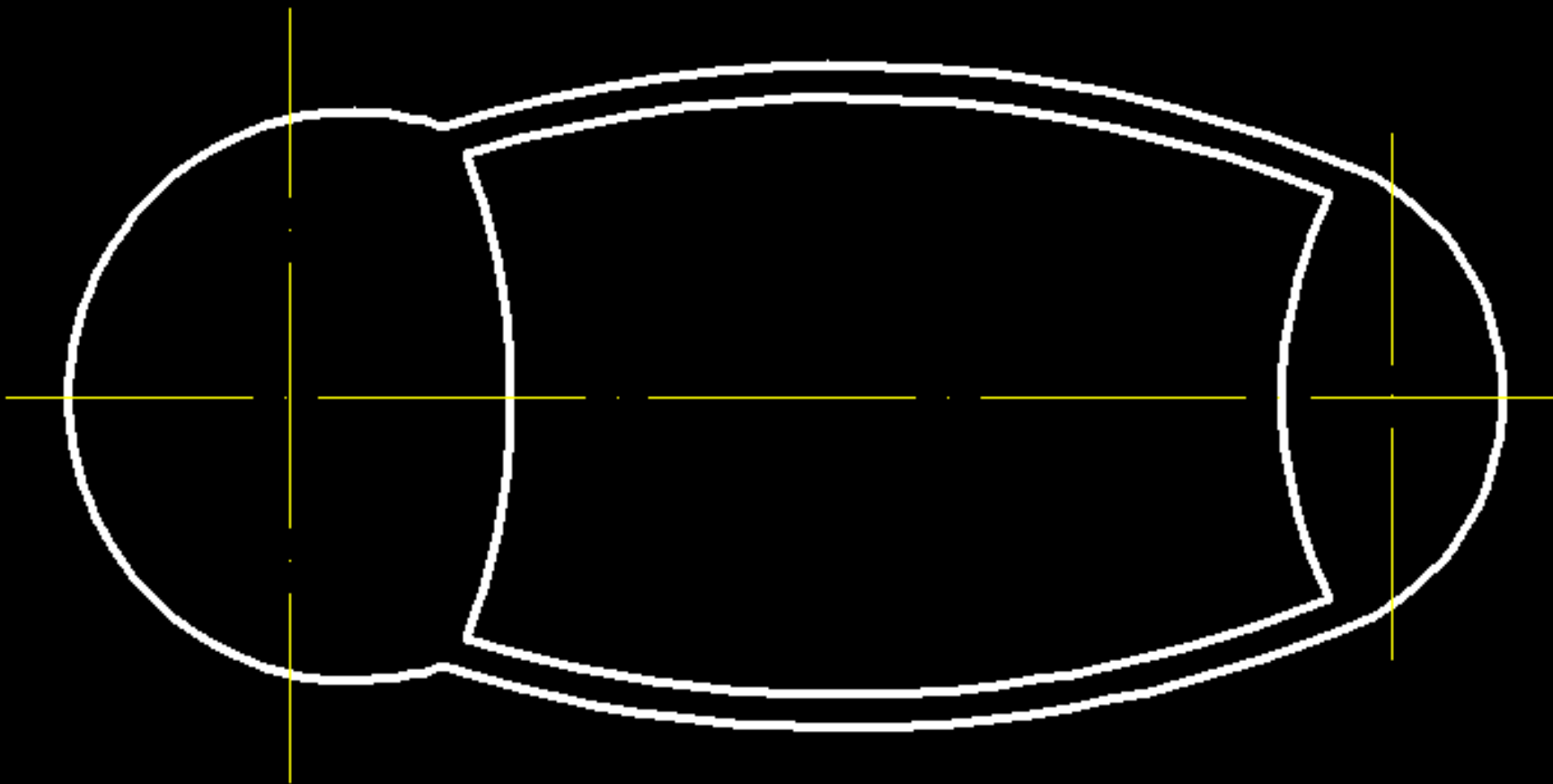

Exercise 39

